

M6夹板螺母 M6 plate nut	M6卡式方螺母 M6 cassette nut	M6法兰螺母 M6 flange nut	M5*10	钉头凹槽规格 screw rut specification T25		
				M6*12	ST5.5*10	ST5.5*10

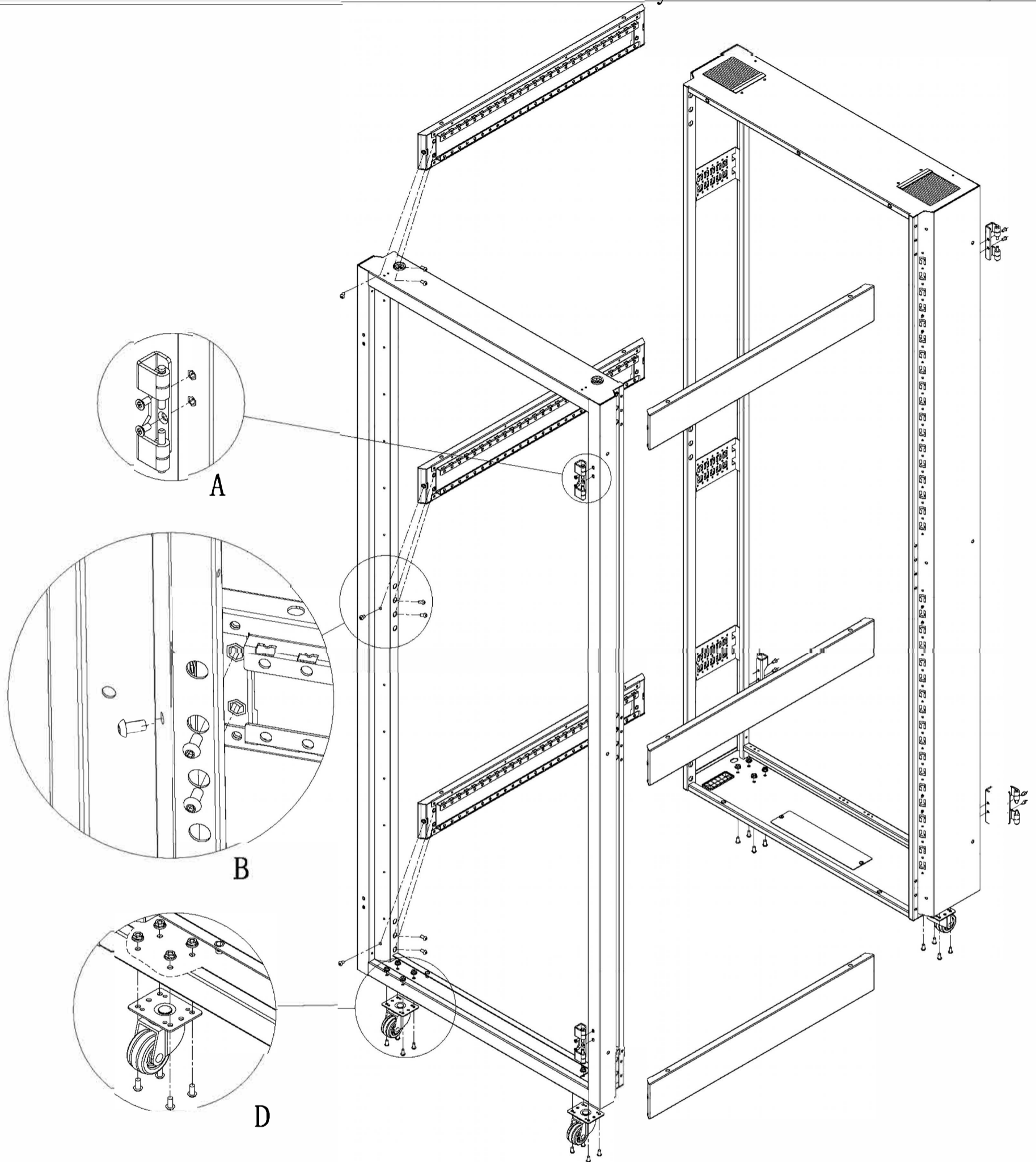

安装步骤: Installation Steps:

1. 使用M6*12螺钉组装侧横梁与前后框架(B), 每个横梁两端各使用3PCS螺钉固定; Use M6*12 screws to assemble the side beams and front and rear frames (B). Use three screws at each end of each beam.
2. 使用M6*12螺钉和M6法兰螺母组装脚轮(D); Assemble the casters (D) by using M6*12 screws and M6 flange nuts.
3. 使用M5*10沉头螺钉安装前后门铰链座(A); Install the front and rear door dumpling chain seat (A) by using M5*10 countersunk screws.

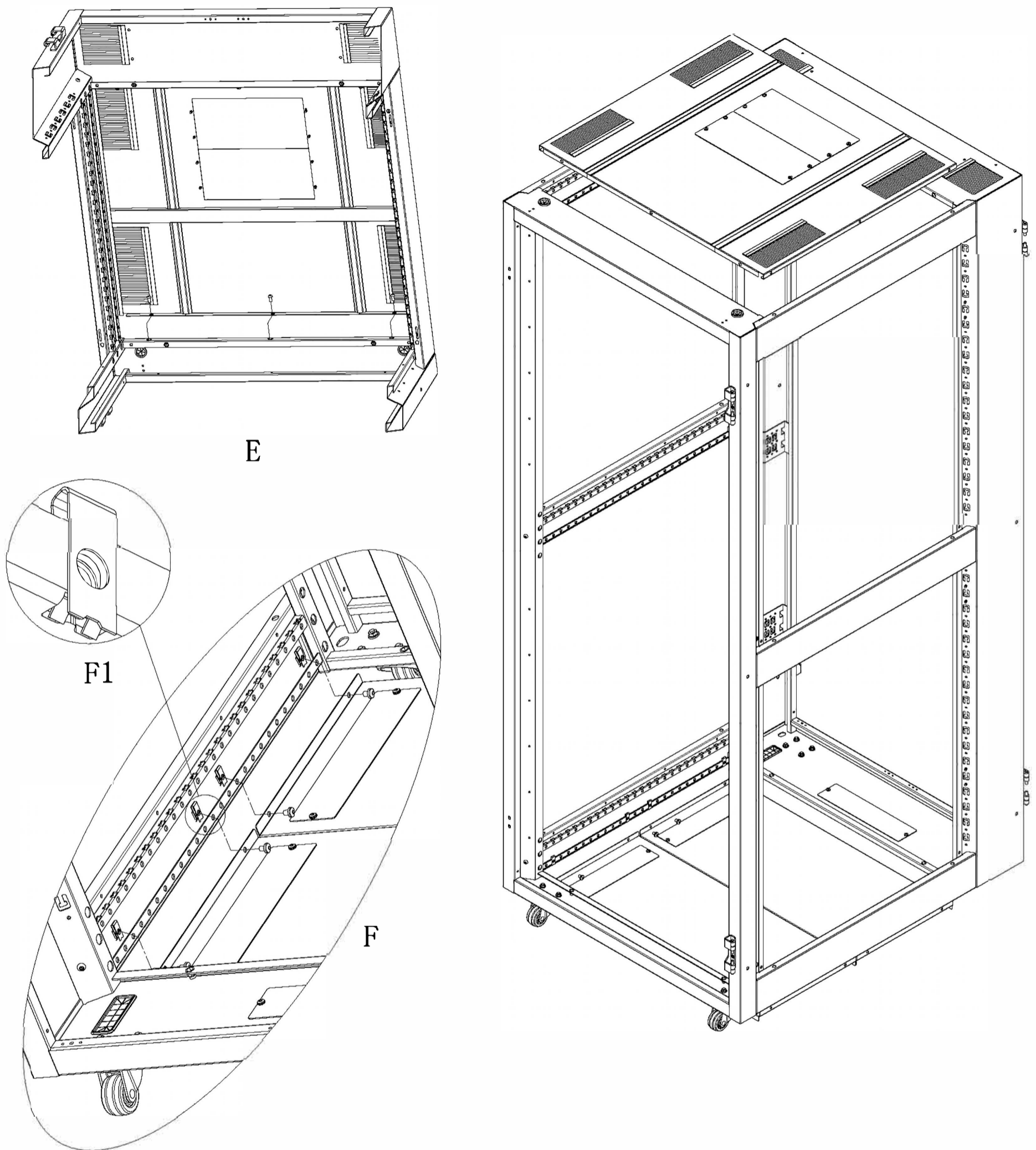

安装步骤: Installation Steps:

4. 使用M6*12螺钉组装机柜顶盖(E), 前后各3PCS螺钉; Use M6*12 screws to assemble the cabinet top cover (E), three screws from the front and rear.
5. 使用M6*12螺钉及M6夹板螺母安装底板(F\F1), 左右2侧各6PCS (4PCS)。
Install the bottom plate (F\F1) with M6*12 screws and M6 cleat nuts, 6PCS (4PCS) on each side of the left and right sides.

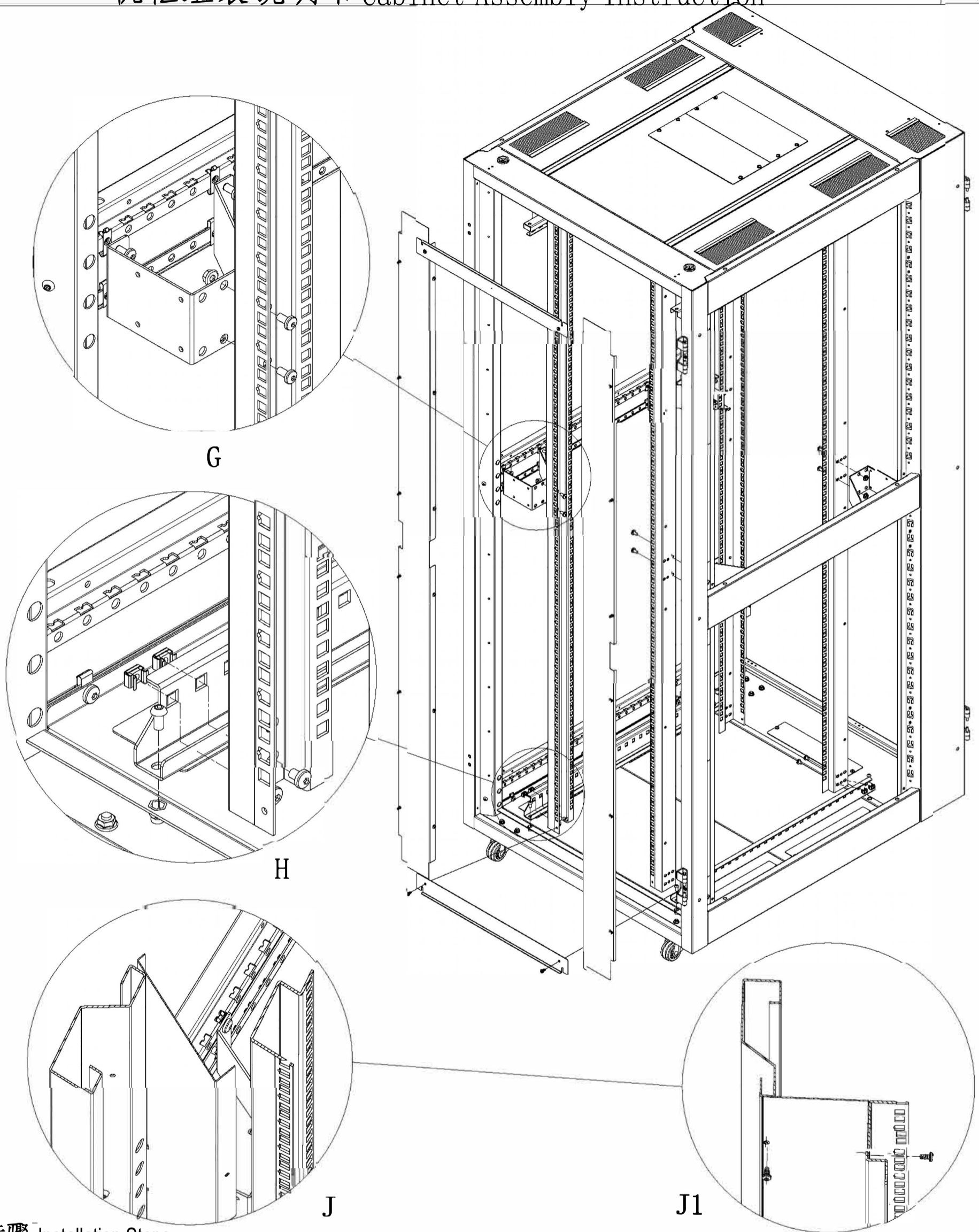

安装步骤: Installation Steps:

6. 使用M6*12螺钉组装方孔条支撑横梁(H)，上下各2PCS; Use M6*12 screws to assemble the mounting profile to support beam (H), with 2PCS on each side.
 7. 使用M6*12螺钉和夹板螺母将方孔条支撑件安装到框架中间横梁上(G); Use M6*12 screws and plate nuts to install the fixing piece on the middle beam (G) of the frame.
 8. 将M6卡式方螺母安装到支撑横梁2端，使用M6*12螺钉将方孔条2端固定在方孔条支撑横梁上(H)，使用M6*12螺钉和M6法兰螺母将方孔条中间固定在支撑件上(G); Install M6 cassette square nuts on both ends of the support beam, secure the two ends of the mounting profile to the support beam by using M6*12 screws (H), and secure the middle of the mounting profile to the supporter by using M6*12 screws and M6 flange nuts (G).
 9. 将方孔条上下挡板使用ST5.5*10自攻钉固定在方孔条两端的孔上；使用ST5.5*10自攻钉将左右挡板固定到方孔条侧面和框架侧面的间隙(JJ1)。
- Fix the upper and lower baffles to the holes at both ends of the mounting profile by using ST5.5*10 tapping nails. Fix the left and right baffle to the gap (JJ1) between the side of the mounting profile and the side of the frame by using ST5.5*10 self-tapping nails.

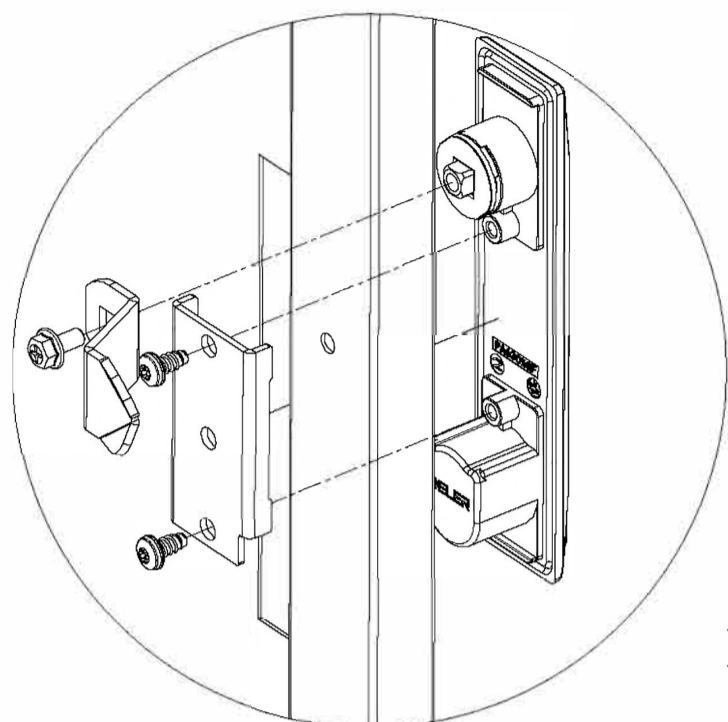

K

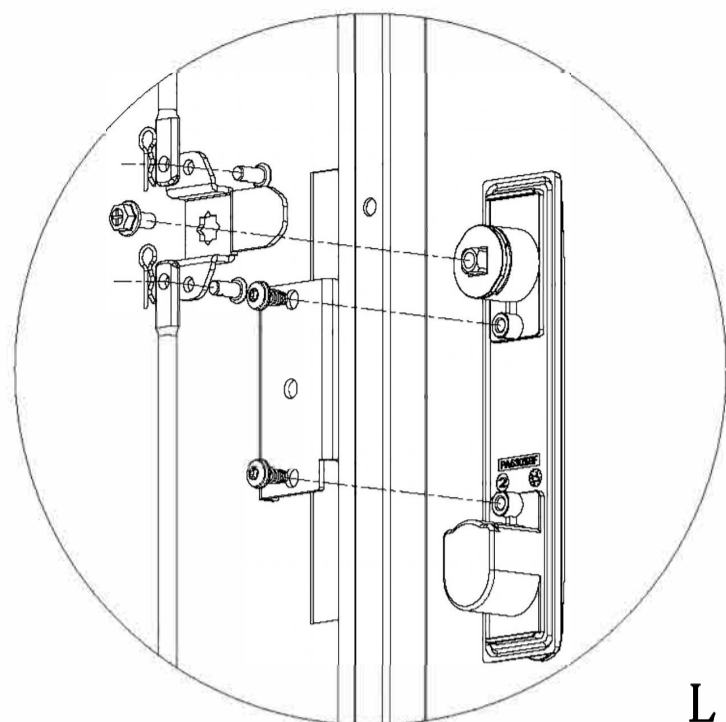

L

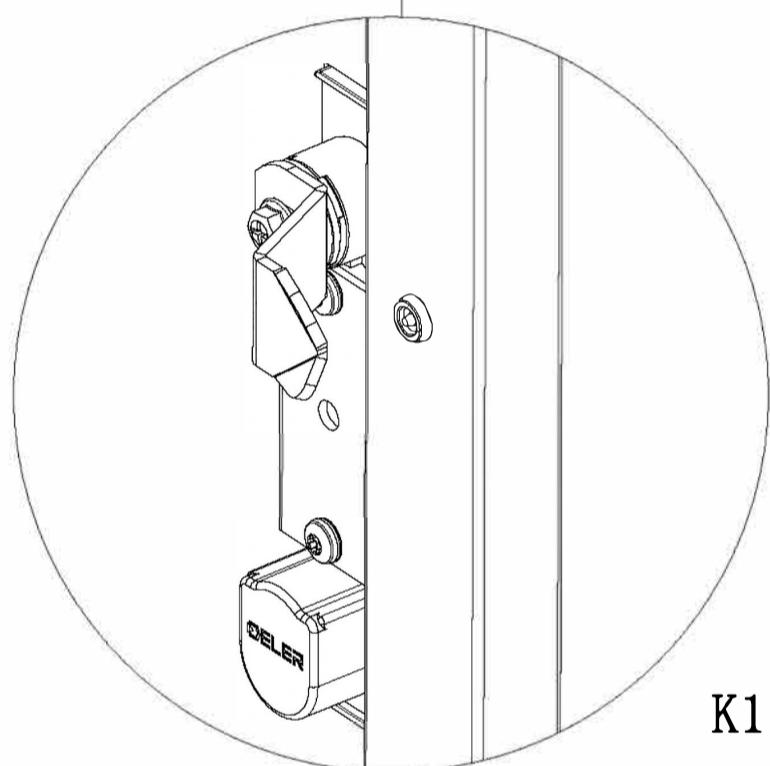

K1

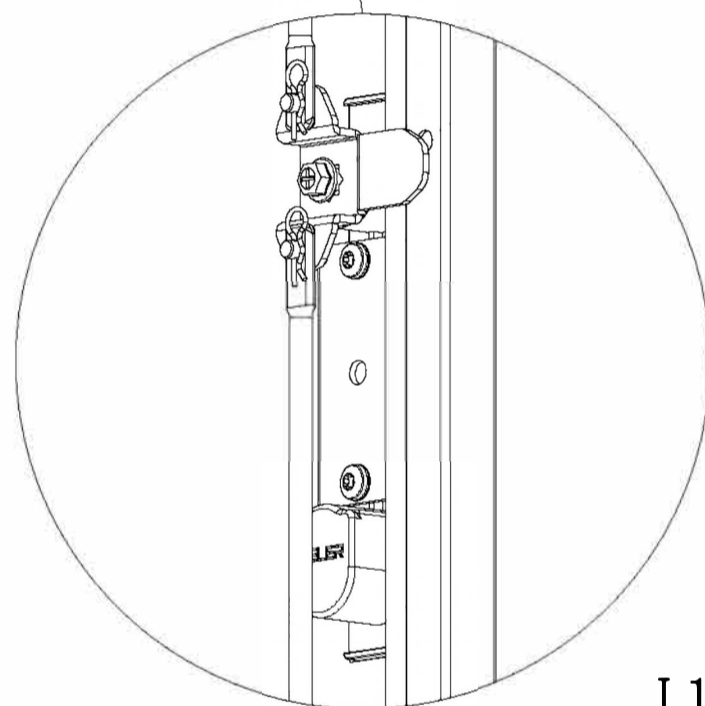

L1

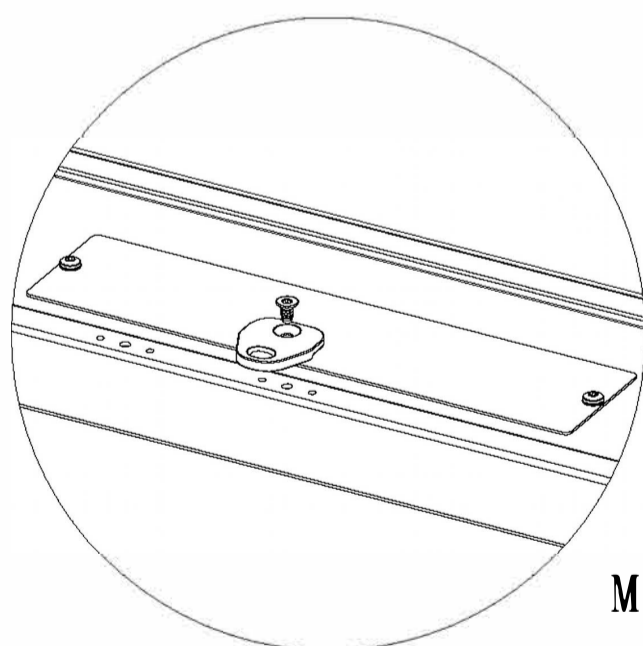

M

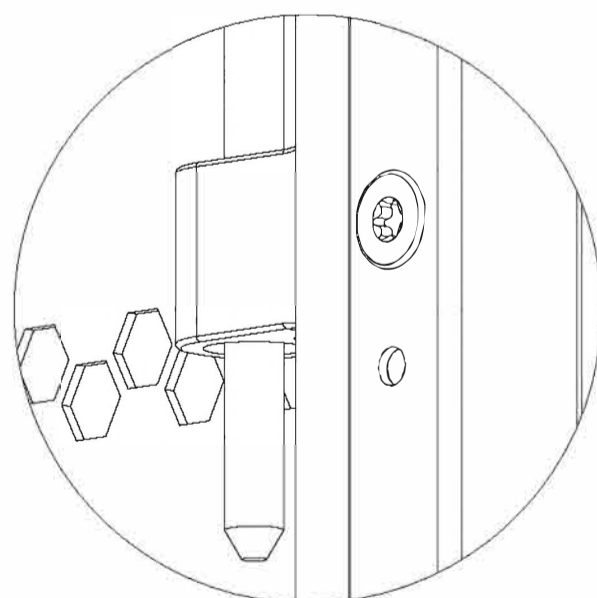

L2

安装步骤: Installation Steps:

10. 组装机柜前门门锁和锁片 (K\K1), 门锁安装固定使用**ST5.5*10**或者**M5*10**自攻钉; Assemble the cabinet front door lock and lock plate (K\K1). ST5.5*10 or M5*10 self-tapping nails are used to fix the door lock.

11. 组装机柜双开右门门锁及锁杆 (L\L1), 注意上下锁杆穿入到导向件内 (L2); Assemble the cabinet double right door lock and lock rod (L\L1), pay attention to the upper and lower lock rod into the guide (L2);

12. 使用**ST5.5*10**沉头螺钉组装机柜上下锁杆挡卡 (M); Use ST5.5*10 countersunk head screws to assemble the cabinet upper and lower lock rod baffle (M).

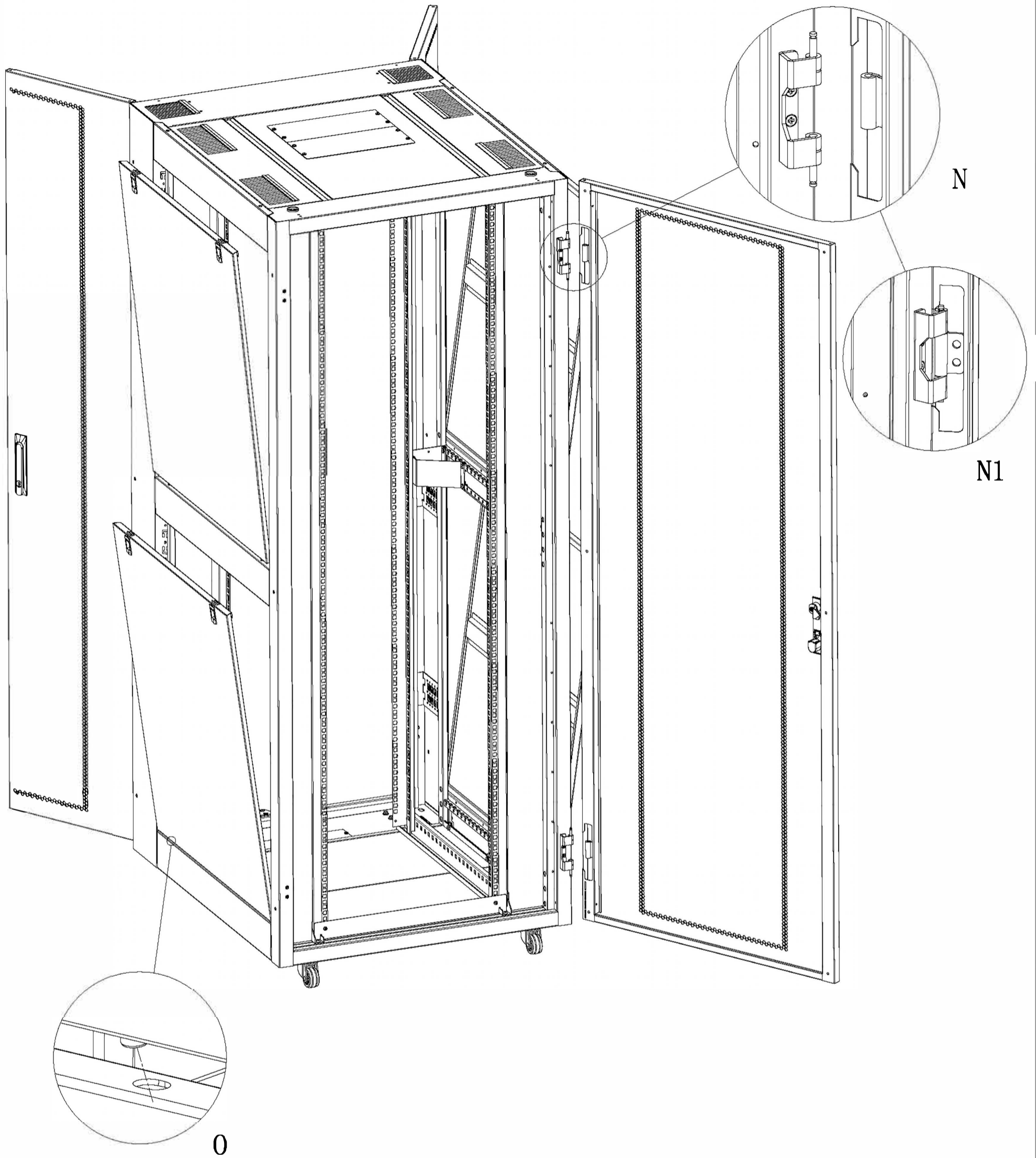

安装步骤 : Installation Steps:

13. 将前后门组装到机柜上, 先将门板上的固定铰链卡入铰座内再将铰座上下插销压到铰座内 (N\N1);
Assemble the front and rear doors on the cabinet, first clamp the fixed hinges on the door panel into the hinge seat, and then press the upper and lower pins of the hinge seat into the hinge seat (N\N1).
14. 安装机柜侧门, 将侧门两边的支脚螺钉斜插入侧横梁安装孔内 (0) 再将侧门箱内推平使拉手插入横梁下侧的卡槽内。 To install the cabinet side door, insert the foot screws on both sides of the side door into the mounting holes (0) in the side beam, and push the side door box flat to insert the handle into the slot at the lower side of the beam.