

Digital VTS

User's Manual







V1.0.2

Foreword

This manual introduces the configurations on local VTS and webpage. Read carefully before using the VTS, and keep the manual safe for future reference.

Safety Instructions

The following signal words might appear in the manual.

Signal Words	Meaning
 DANGER	Indicates a high potential hazard which, if not avoided, will result in death or serious injury.
 WARNING	Indicates a medium or low potential hazard which, if not avoided, could result in slight or moderate injury.
 CAUTION	Indicates a potential risk which, if not avoided, could result in property damage, data loss, reductions in performance, or unpredictable results.
 TIPS	Provides methods to help you solve a problem or save time.
 NOTE	Provides additional information as a supplement to the text.

Revision History

Version	Revision Content	Release Time
V1.0.2	Revised basic services and device setting.	January 2024
V1.0.1	Revised advanced parameters.	June 2023
V1.0.0	First release.	November 2022

Privacy Protection Notice

As the device user or data controller, you might collect the personal data of others such as their face, audio, fingerprints, and license plate number. You need to be in compliance with your local privacy protection laws and regulations to protect the legitimate rights and interests of other people by implementing measures which include but are not limited to: Providing clear and visible identification to inform people of the existence of the surveillance area and provide required contact information.

About the Manual

- The manual is for reference only. Slight differences might be found between the manual and the product.
- We are not liable for losses incurred due to operating the product in ways that are not in compliance with the manual.
- The manual will be updated according to the latest laws and regulations of related jurisdictions. For detailed information, see the paper user's manual, use our CD-ROM, scan the QR code or

visit our official website. The manual is for reference only. Slight differences might be found between the electronic version and the paper version.

- All designs and software are subject to change without prior written notice. Product updates might result in some differences appearing between the actual product and the manual. Please contact customer service for the latest program and supplementary documentation.
- There might be errors in the print or deviations in the description of the functions, operations and technical data. If there is any doubt or dispute, we reserve the right of final explanation.
- Upgrade the reader software or try other mainstream reader software if the manual (in PDF format) cannot be opened.
- All trademarks, registered trademarks and company names in the manual are properties of their respective owners.
- Please visit our website, contact the supplier or customer service if any problems occur while using the device.
- If there is any uncertainty or controversy, we reserve the right of final explanation.

Important Safeguard and Warnings

This section introduces content covering the proper handling of the device, hazard prevention, and prevention of property damage. Read carefully before using the device, and comply with the guidelines when using it.

Installation Requirements



WARNING

- Do not connect the power adapter to the device while the adapter is powered on.
- Do not connect the device to two or more kinds of power supplies, to avoid damage to the device.
- Please follow the electrical requirements to power the device.
 - ◇ Following are the requirements for selecting a power adapter.
 - The power supply must conform to the requirements of IEC 60950-1 and IEC 62368-1 standards.
 - The voltage must meet the SELV (Safety Extra Low Voltage) requirements and not exceed ES-1 standards.
 - When the power of the device does not exceed 100 W, the power supply must meet LPS requirements and be no higher than PS2.
 - ◇ We recommend using the power adapter provided with the device.
 - ◇ When selecting the power adapter, the power supply requirements (such as rated voltage) are subject to the device label.



- Personnel working at heights must take all necessary measures to ensure personal safety including wearing a helmet and safety belts.
- Do not place the device in a place exposed to sunlight or near heat sources.
- Keep the device away from dampness, dust, and soot.
- Install the device on a stable surface to prevent it from falling.
- Install the device in a well-ventilated place, and do not block its ventilation.
- Use an adapter or cabinet power supply provided by the manufacturer.
- Use the power cords that are recommended for the region and conform to the rated power specifications.
- The device is a class I electrical appliance. Make sure that the power supply of the device is connected to a power socket with protective earthing.

Operation Requirements



DANGER

Battery Pack Precautions

Preventive measures (including but not limited to):

- Do not transport, store or use the batteries in high altitudes with low pressure and environments with extremely high and low temperatures.
- Do not dispose the batteries in fire or a hot oven, or mechanically crush or cut the batteries to avoid an explosion.

- Do not leave the batteries in environments with extremely high temperatures to avoid explosions and leakage of flammable liquid or gas.
- Do not subject the batteries to extremely low air pressure to avoid explosions and the leakage of flammable liquid or gas.



- Check whether the power supply is correct before use.
- Do not unplug the power cord on the side of the device while the adapter is powered on.
- Operate the device within the rated range of power input and output.
- Transport, use and store the device under allowed humidity and temperature conditions.
- If the device is powered off for longer than a month, it should be placed in its original package and sealed. Make sure to keep it away from moisture, and store it under allowed humidity and temperature conditions.
- Do not drop or splash liquid onto the device, and make sure that there is no object filled with liquid on the device to prevent liquid from flowing into it.
- Do not disassemble the device without professional instruction.

Table of Contents

Foreword.....	I
Important Safeguard and Warnings.....	III
1 Device Structure.....	1
1.1 Front Panel.....	1
1.2 Rear Panel.....	3
2 Initializing VTS.....	5
2.1 Initialization through Local Device.....	5
2.2 Initialization through Webpage.....	5
3 Building Scenes.....	7
3.1 Operations on Local Device.....	7
3.1.1 Local Screen.....	7
3.1.2 Configuring the Display Parameters.....	8
3.1.3 Configuring the Sound Parameters.....	8
3.1.4 Configuring the Intercom Parameters.....	9
3.1.5 Configuring the Advanced Parameters.....	10
3.1.6 Resetting Password.....	11
3.1.7 Project Settings.....	12
3.1.8 Commissioning.....	18
3.2 Operations on Webpage.....	23
3.2.1 Logging in to the Webpage.....	23
3.2.2 Resetting Password.....	24
3.2.3 Home Page Introduction.....	25
3.2.4 Configuring Network.....	26
3.2.5 System Management.....	30
3.2.6 Device Management.....	39
3.2.7 Log.....	41
3.2.8 Security.....	42
4 Industrial Scenes.....	53
4.1 Operations on Local Device.....	53
4.1.1 Local Screen.....	53
4.1.2 Configuring Intercom Parameters.....	54
4.1.3 Configuring the Advanced Parameters.....	54
4.1.4 Project Settings.....	55
4.1.5 Commissioning.....	56
4.2 Operations on Webpage.....	61
4.2.1 Configuring Device Role.....	62

4.2.2	Configuring SIP Server.....	62
4.2.3	Configuring FTP.....	63
4.2.4	Device Setting.....	64
Appendix 1	Cybersecurity Recommendations.....	69

1 Device Structure

1.1 Front Panel

Figure 1-1 Front panel

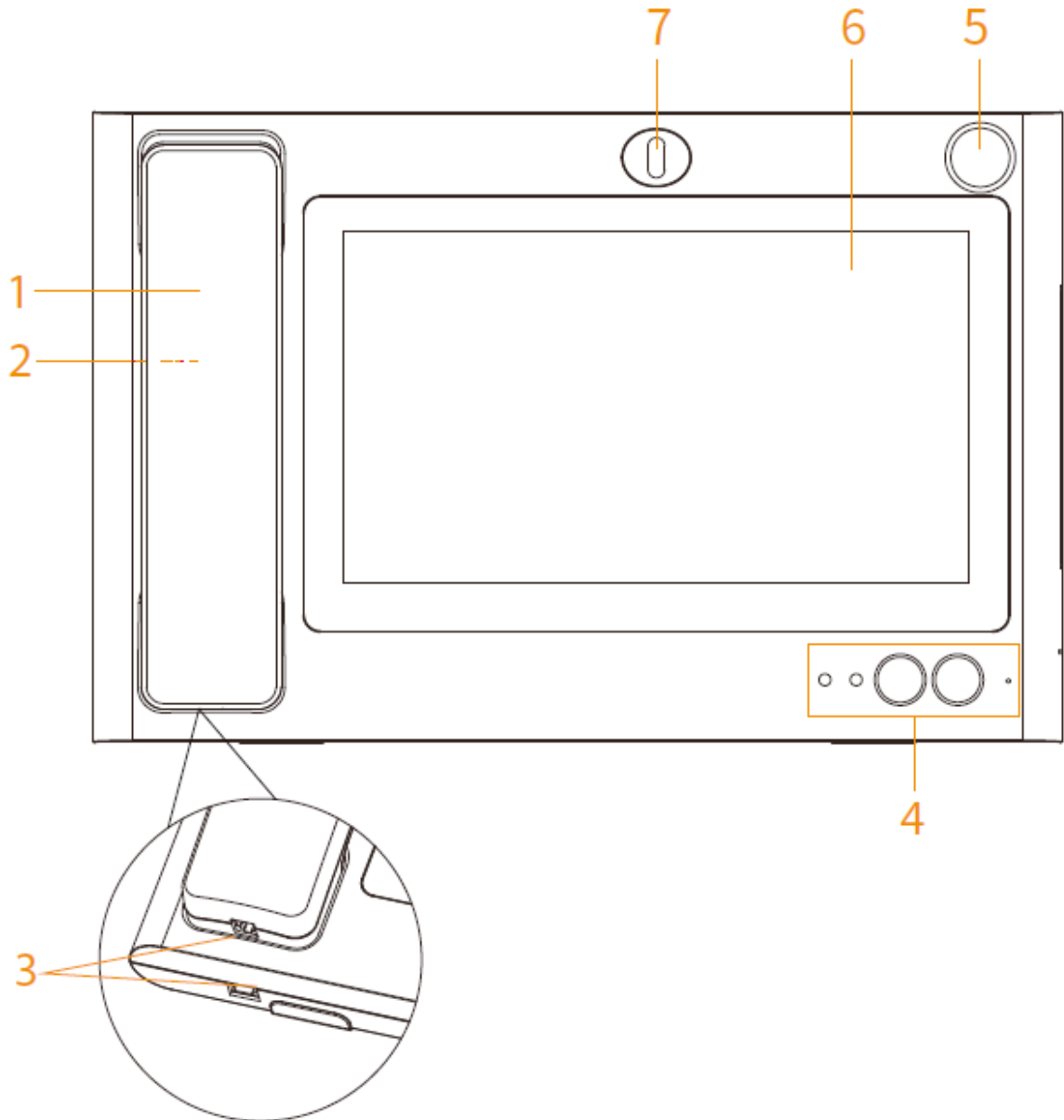





Table 1-1 Front panel description

No.	Name	Description
1	MIC	If you lift MIC, audio and pickup are both converted into MIC.
2	Speaker	Outputs sound.
3	RJ-11 Port	Connects VTS and MIC using the telephone cord.

No.	Name	Description
4	Indicator/Button	<p>From left to right:</p> <ul style="list-style-type: none"> ● Power indicator <ul style="list-style-type: none"> ◇ On: The device is powered on. ◇ Off: The device is not connected to the power supply. ● Information indicator <ul style="list-style-type: none"> ◇ On: There is a missed call. ◇ Off: The missed call has been processed or there is no missed call. <p></p> <p>In the industrial scene, if the indicator is on, it indicates that the device has unread alarm records.</p> <ul style="list-style-type: none"> ● Unlock button <p>When you are making calls, watching videos, or talking to others through the VTS, press the unlock button, you can remotely open the door of some front-end devices that support unlocking function.</p> ● Hands-free button <p>Used to answer incoming calls. You can select hands free mode or handset mode.</p> ● Built-in MIC <p>Inputs sound.</p>
5	Gooseneck Microphone Port	<p>Connects to a gooseneck microphone.</p> <p></p> <p>The port is available on select models.</p>
6	Display and Touch	Screen and touch area.
7	Camera	<p>Used to talk with another VTS or the platform.</p> <p></p> <p>The camera is available on select models.</p>

1.2 Rear Panel

Figure 1-2 Rear panel

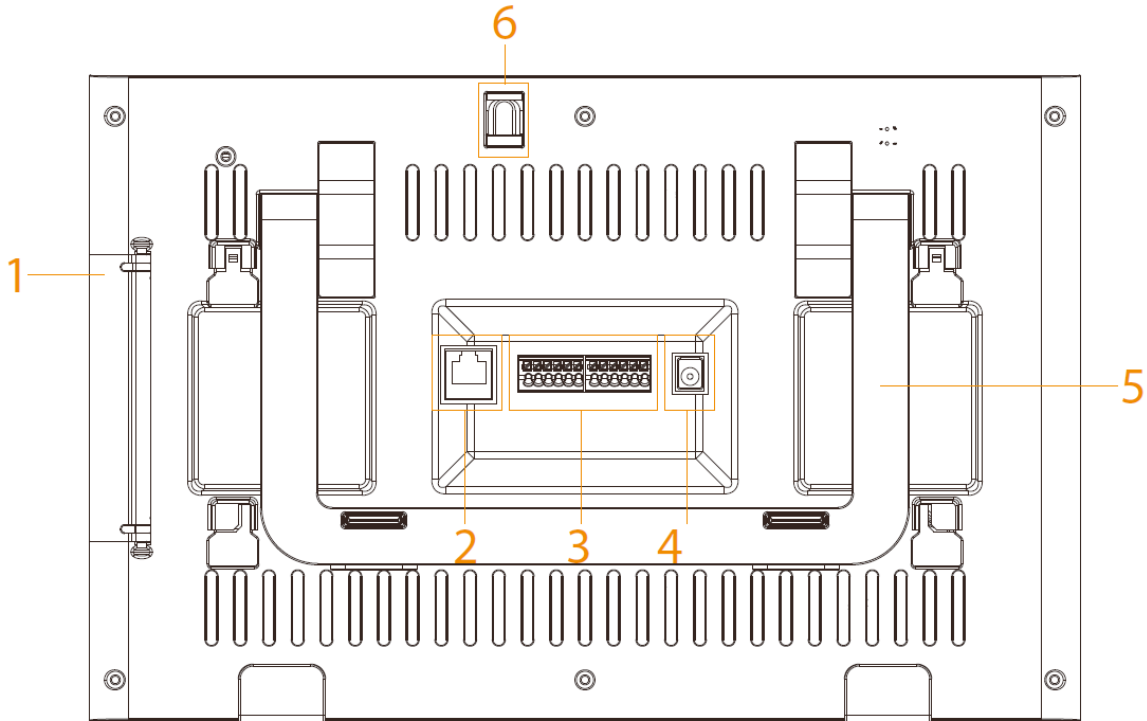



Table 1-2 Rear panel description

No.	Name	Description
1	Port	<p>Open the rear panel and the ports from top to bottom are:</p> <ul style="list-style-type: none"> ● HDMI video transmission port, for video transmission only. ● USB port. ● USB port. ● SD card slot.
2	Network Port	<p>Connects RJ-45 cable.</p>  <p>We recommend you use FTP (Foil Twisted-Pair).</p>

No.	Name	Description
3	12-pin Port	Ports from left to right are: <ul style="list-style-type: none"> ● Power output port. ● GND. ● Alarm input port 1. ● Alarm input port 2. ● Alarm input port 3. ● Alarm input port 4. ● Power input port. ● GND. ● RS-485A port. ● RS-485B port. ● Alarm output port NO. ● Alarm output port COM.
4	Power Port	12 VDC power.
5	Bracket	Place VTS on the desk. You can adjust the bracket angle to an appropriate position for monitoring.
6	Camera Knob	You can adjust the knob to an appropriate angel for monitoring. You can also hide the camera by adjusting the knob.  The knob is available on select models.

2 Initializing VTS

You can initialize VTS through the local device or through the webpage.

2.1 Initialization through Local Device

Procedure

- Step 1 Power on the VTS.
- Step 2 Select the language.
- Step 3 Enter the password and e-mail address.
- Step 4 Select **I have read and agree to all the terms Privacy, Software License Agreement** , and then tap **Next**.
- Step 5 Select the scene depending on your needs.

Figure 2-1 Initialization through local device

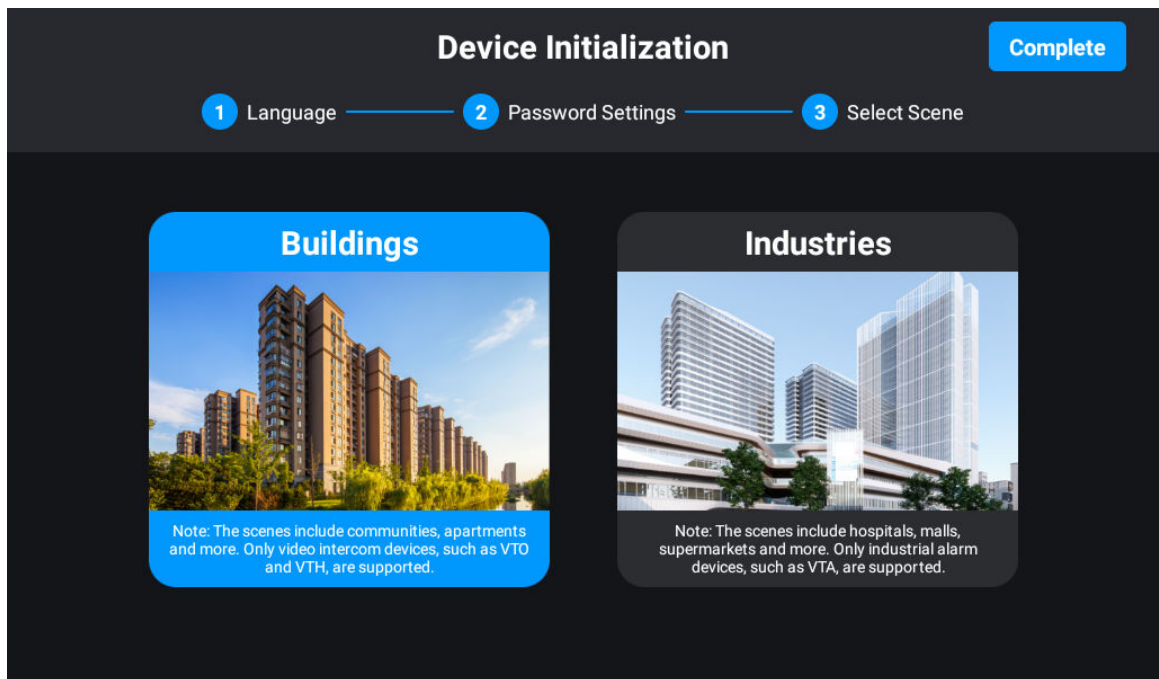

- Step 6 Tap **Complete**.

2.2 Initialization through Webpage

Prerequisites

Make sure that the computer is on the same network segment as VTS.

Procedure

- Step 1 Enter the IP address of VTS in a browser, and then click **Enter**.
- Step 2 Select the language.
- Step 3 If there are agreements, select **I have read and agree to the terms and conditions and accept privacy policy and license agreement** , and then click **Next**.
- Step 4 Enter the password and e-mail address, and then click **Completed**.

Step 5 Enter the username and password, and then click **Login**.

Step 6 Select the scene, and then click **OK**.

Figure 2-2 Select scene

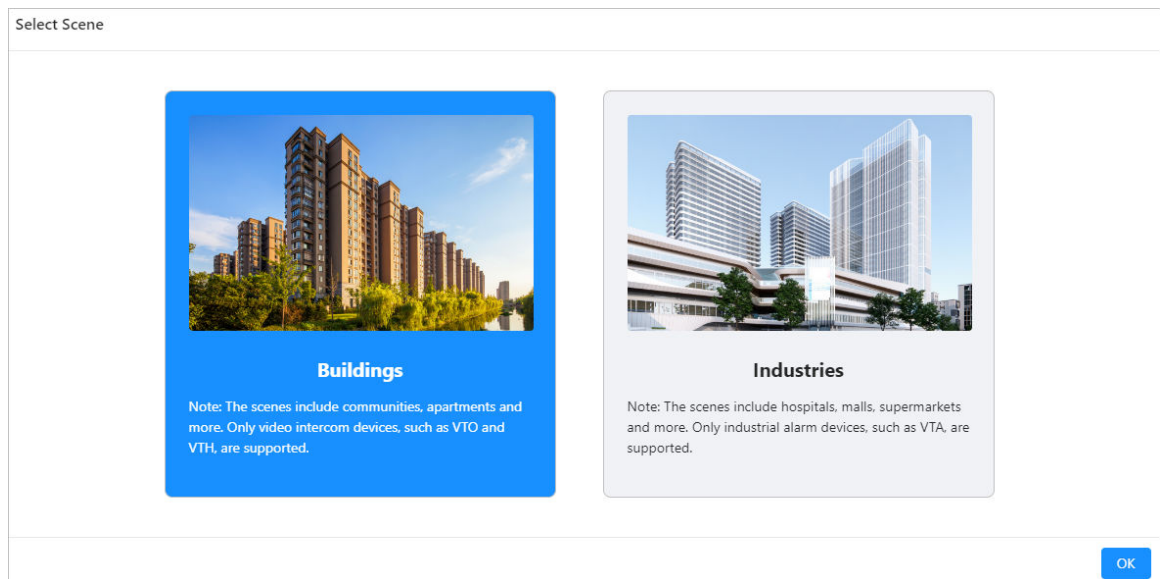

3 Building Scenes

3.1 Operations on Local Device

3.1.1 Local Screen

Figure 3-1 Local screen

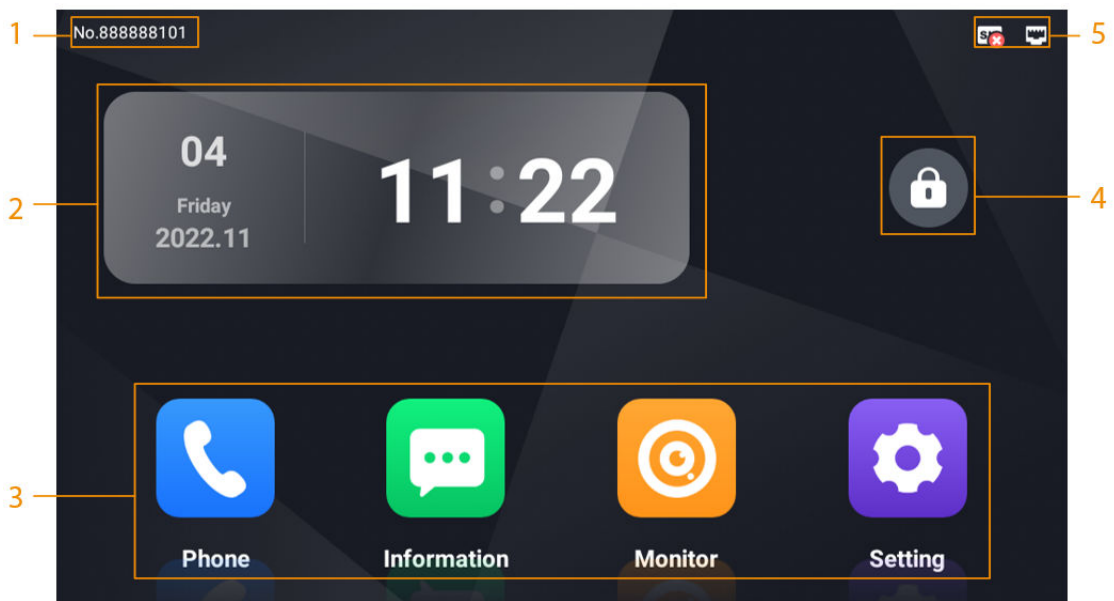



Table 3-1 Home screen introduction

No.	Description
1	The number of VTS.
2	Date and time.
3	Function buttons. <ul style="list-style-type: none"> • Phone: Call VTH and check the call history. For details, see "3.1.8.1 Call". • Information: Check the video playback and screenshots. For details, see "3.1.8.2 Checking the Information". • Monitor: Monitor VTH, VTO and IPC. For details, see "3.1.8.3 Monitoring". • Setting: Enter the setting screen of VTS.
4	Tap  to lock the screen.  If you select Setting > Display Settings , and turn on Lock Screen , you need to enter the default password 123456 to unlock the screen when you lock it after the configuration.

No.	Description
5	The connection status of the network, the SIP server, and the SD card.

3.1.2 Configuring the Display Parameters

Configure the brightness and screen turn-off time. Turn on or turn off **Lock Screen**.

Procedure

Step 1 On the home screen, select **Setting** > .

Step 2 Configure the parameters.

Lock screen: After turning on the function, if you need to unlock the screen again, enter the default password **123456**.

Figure 3-2 Display settings

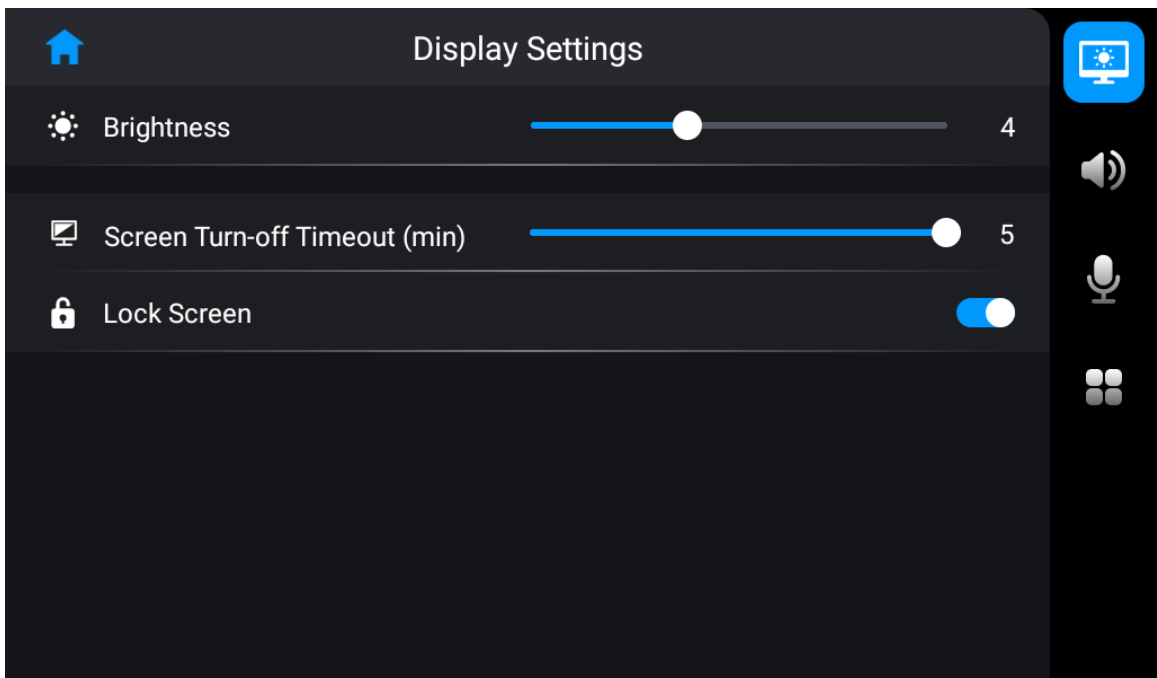

3.1.3 Configuring the Sound Parameters

Procedure

Step 1 On the home screen, select **Setting** > .

Step 2 Configure the parameters.

Figure 3-3 Sound settings

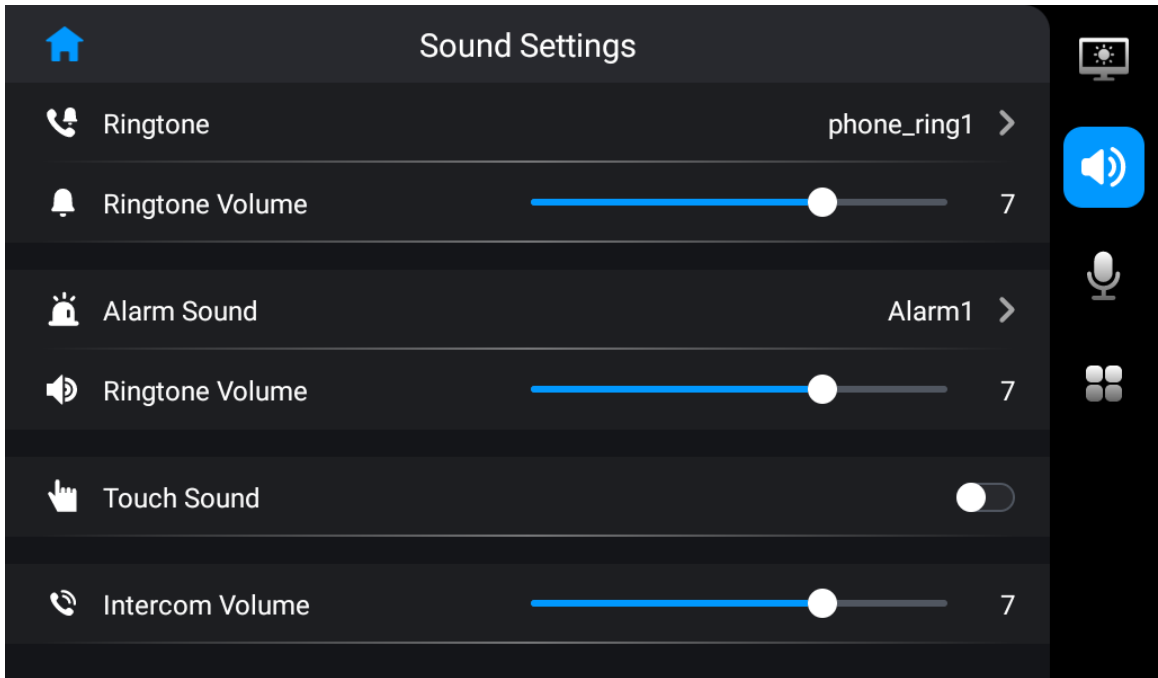

3.1.4 Configuring the Intercom Parameters

Configure the ringtone and call limit of VTO and VTH, and the monitoring time.

Procedure

Step 1 On the home screen, select **Setting** > .

Step 2 Configure the parameters.

Figure 3-4 Intercom settings

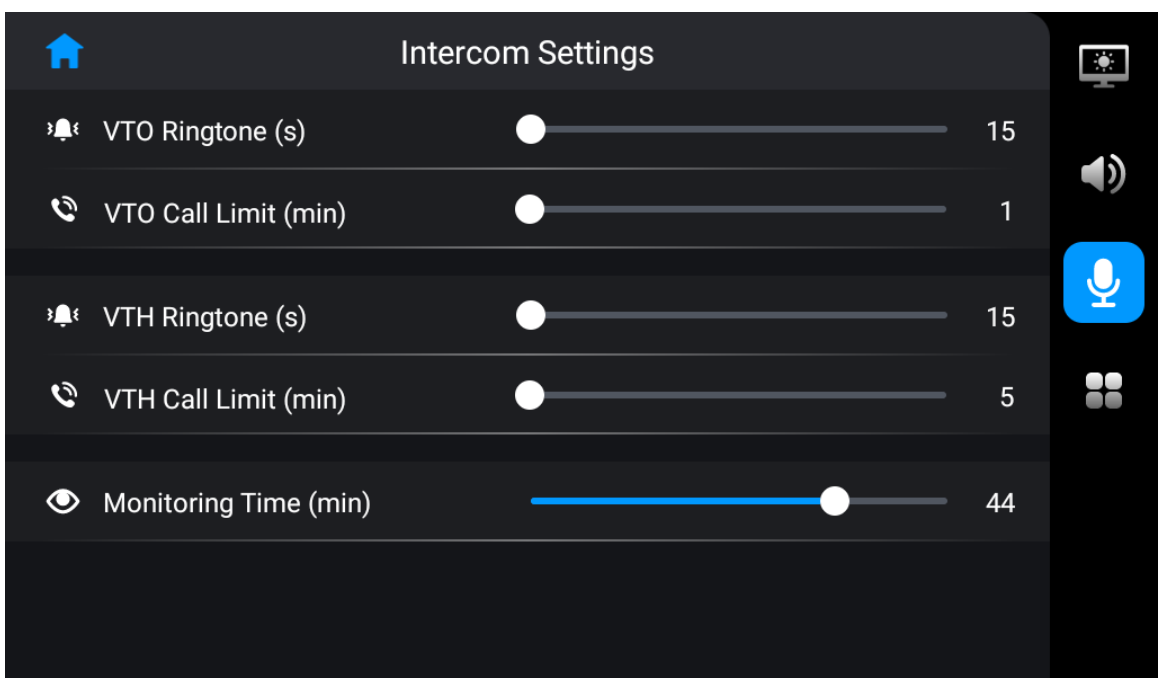

Table 3-2 Description of intercom parameters

Parameter	Description
VTO Ringtone (s)	The call from VTO stops ringing after the time you set.
VTO Call Limit (min)	VTO automatically hangs up the call to VTS after the time you set.
VTH Ringtone (s)	The call from VTH stops ringing after the time you set.
VTH Call Limit (min)	VTH automatically hangs up the call to VTS after the time you set.
Monitoring Time (min)	The time that VTS monitor VTO and other devices.

3.1.5 Configuring the Advanced Parameters

Procedure

- Step 1 On the home screen, select **Setting** > .
- Step 2 Configure the parameters.

Figure 3-5 Advanced settings

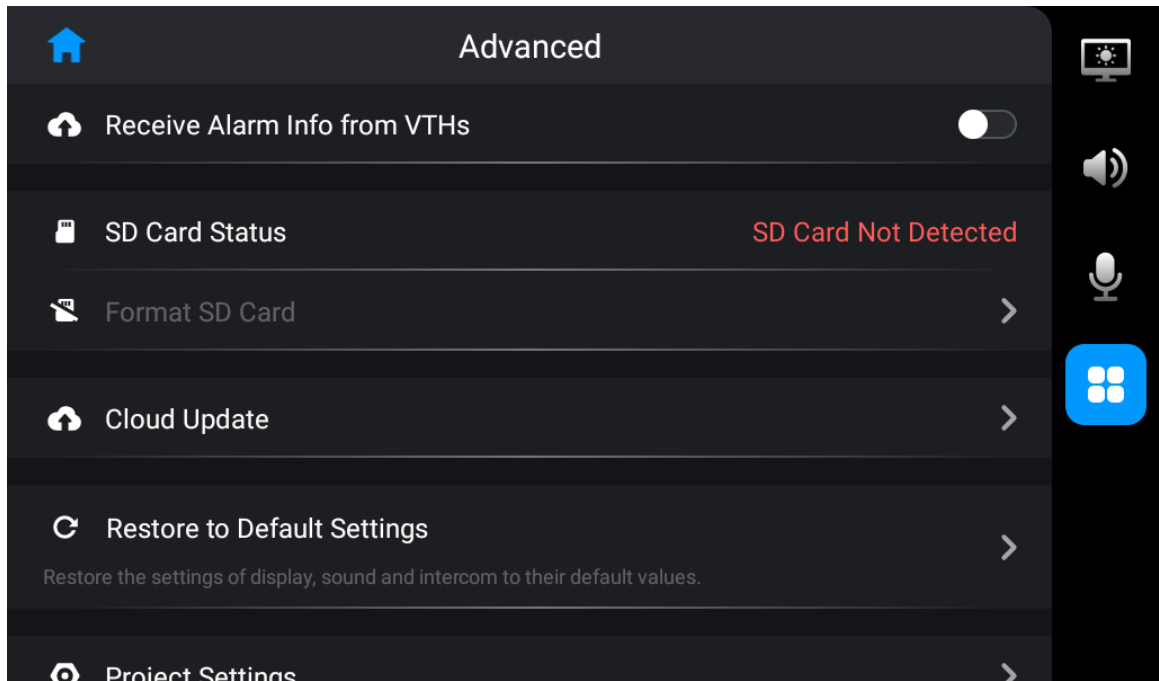



Table 3-3 Advanced settings description

Parameter	Description
SD Card Status	<p>Check the used capacity and the total capacity of the SD card if there is a SD card in VTS.</p>  <p>System of numeration differs in Android system and Windows system when converting the capacity. So the capacity of the SD card displayed on VTS is larger than that displayed on the computer.</p>
Format SD Card	Supports formatting the SD card.
Cloud Update	Check the latest version through the interactions with the cloud, and then update online.
Restore to Default Settings	Restore the display, sound and intercom settings to default settings.
Project Settings	Enter the initial password to enter the project settings screen. For details, see "3.1.7 Project Settings".
Device Info	View the legal information, version and security baseline version of VTS.

3.1.6 Resetting Password

You can reset the password through the linked e-mail address.

Prerequisites

Make sure that you have turned on **Reset Info** in **Project Settings**. For details, see "3.1.7.4 Resetting Information".

Procedure

- Step 1 On the home screen, select **Setting** >  > **Project Settings**.
- Step 2 Tap **Forget password?**, and then tap **OK**.

Figure 3-6 Reset password



Step 3 Get the **Security Code** according to the instructions, and then enter the new password and security code.

Step 4 Tap **OK**.

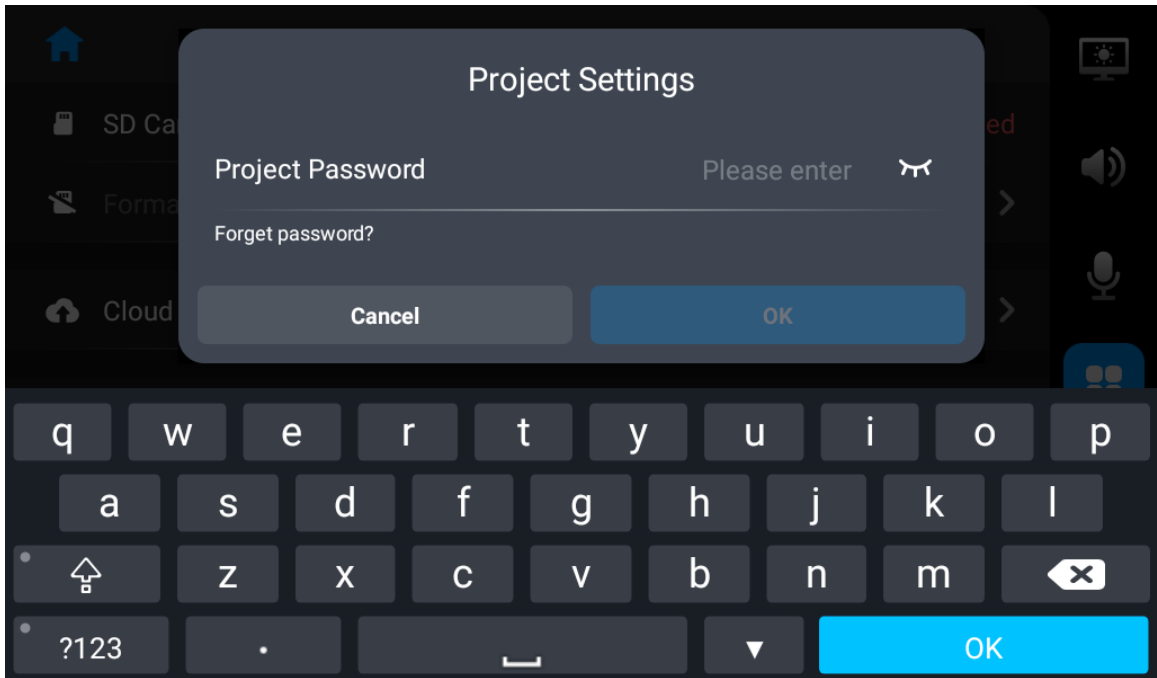
3.1.7 Project Settings

3.1.7.1 Configuring VTS

Configure the number and network parameters of VTS.

Procedure



- Step 1 Select **Settings** >  > **Project Setting** on the home screen.
- Step 2 Enter the password that you configured during initialization and tap **OK**.
- Step 3 Tap  and configure the parameters.

Figure 3-7 Configure the parameters

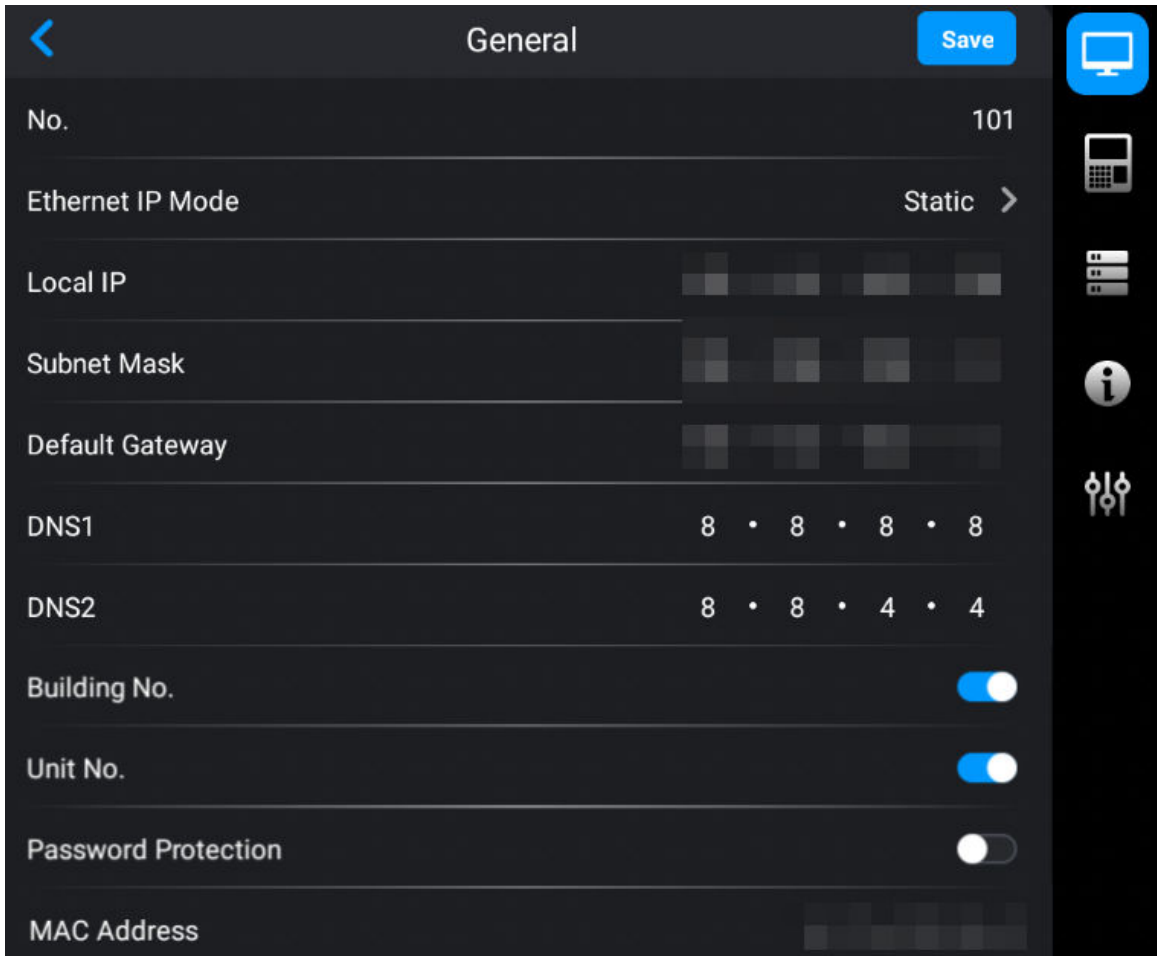



Table 3-4 Parameters description

Parameter	Description
No.	User-defined. You can configure the number from 101 to 999.
Ethernet IP Mode	Configure the mode to get the IP. <ul style="list-style-type: none"> • Static: Manually set Local IP , Subnet Mask and Default Gateway. • DHCP (Dynamic Host Configuration Protocol): Select DHCP if there is a DHCP server. The device automatically gets a dynamic IP address.
Local IP	If you select Static in Ethernet IP Mode , configure the IP address, subnet mask and default gateway according to the network planning.
Subnet Mask	
Default Gateway	
DNS 1	IP address of DNS server.
DNS 2	Standby IP address of DNS server.

Parameter	Description
Building No.	<ul style="list-style-type: none"> If the platform is used as the SIP server, make sure that the configuration status of building and unit number is the same on the platform, VTS and VTO. If the VTO is used as the SIP server, make sure that the enable/disable status of building and unit number is the same on VTS and VTO.  <p>You cannot get the device information of VTO on the monitoring screen.</p>
Unit No.	
Password Protection	Turn on password protection. The password is transferred in encryption when the device is registered on the platform through SIP.

3.1.7.2 Configuring SIP Server

Configure the parameters of SIP server. Connect to VTO through SIP agreement to achieve video intercom.

Procedure

Step 1 Select **Setting** >  > **Project Setting** on the home screen.

Step 2 Enter the password and tap **OK**.

Step 3 Tap  and configure the parameters.

Figure 3-8 Configure the parameters



Table 3-5 Parameters description

Parameter	Description
IP Address	IP address of SIP server.

Parameter	Description
Network Port	Network port number of SIP server. <ul style="list-style-type: none"> • VTO as the SIP server: 5060. • The platform as the SIP server: 5080.
Username	Default.
Password	Default.
Domain Name	Keep consistent with the SIP server. Domain name is VDP by default.

Step 4 Tap **Save**.

3.1.7.3 Adding Devices

Add VTO, fence station or IPC to the VTS, and then you can monitor VTO, fence station or IPC, remotely unlock and talk to VTO or fence station on the VTS.

Procedure



- Step 1 Select **Settings** >  > **Project Setting** on the home screen.
- Step 2 Enter the password that you configured during initialization and tap **OK**.
- Step 3 Select  > **Add device**.
- Step 4 Add devices.
- Add device one by one.

Figure 3-9 Add device one by one



- Add devices in batches.

Figure 3-10 Add devices in batches

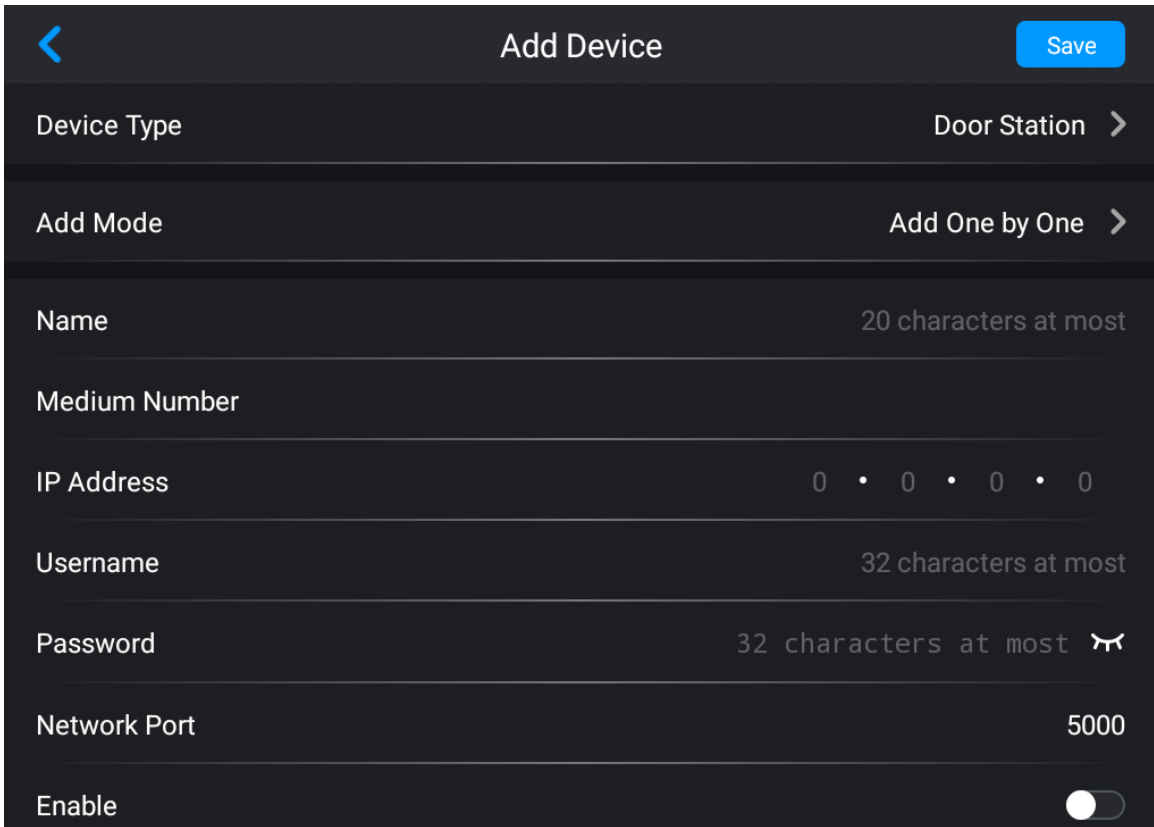
Table 3-6 Parameters description

Device Type	Parameter	Description
Door Station or Fence Station	Add Mode	Supports adding devices one by one or in batches. Only VTO supports adding devices in batches.
	Name	User-defined. You can configure the name that distinguishes the device.
	Medium Number	Cannot be edited.
	IP Address	The IP, username and password of the device that you added.
	Username	
	Password	
	Enable	After turning on, select Monitor > VTO or Monitor > Fence Station to monitor the screen.
	Start IP	The start and end IP address of the device if you add devices in batches.
	End IP	
IPC	Name	User-defined. You can configure the name that distinguishes the device.
	No.	User-defined.
	IP Address	The IP, username and password of the device that you added.
	Username	
	Password	

Device Type	Parameter	Description
	Stream Type	Select main stream or sub stream. <ul style="list-style-type: none"> ● Main stream: Large stream has high definition, and occupies a large bandwidth. Used for local storage. ● Sub stream: Smooth image occupies a small bandwidth. Used for low-bandwidth network transmission.
	Protocol Type	Select the local protocol or ONVIF protocol depending on the IPC that you added.
	Encryption	The video is transferred in encryption when this function is turned on.
	Linkage	VTH supports displaying the image of connected IPC when VTS calls VTH if you turn on this function.

Step 5 Tap **Save**.

3.1.7.4 Resetting Information

Turn on the resetting function here, otherwise you cannot reset password if you forget it.

Procedure



- Step 1 On the home screen, select **Setting** >  > **Project Settings**.
- Step 2 Enter the password that you configured during initialization, and then tap **OK**.
- Step 3 Tap .
- Step 4 Turn on **Reset Password**.
- Step 5 Tap **Bound Email** to enter the e-mail address.

Figure 3-11 Reset information



Step 6 Click **OK**.

3.1.7.5 Debugging and Factory Defaults

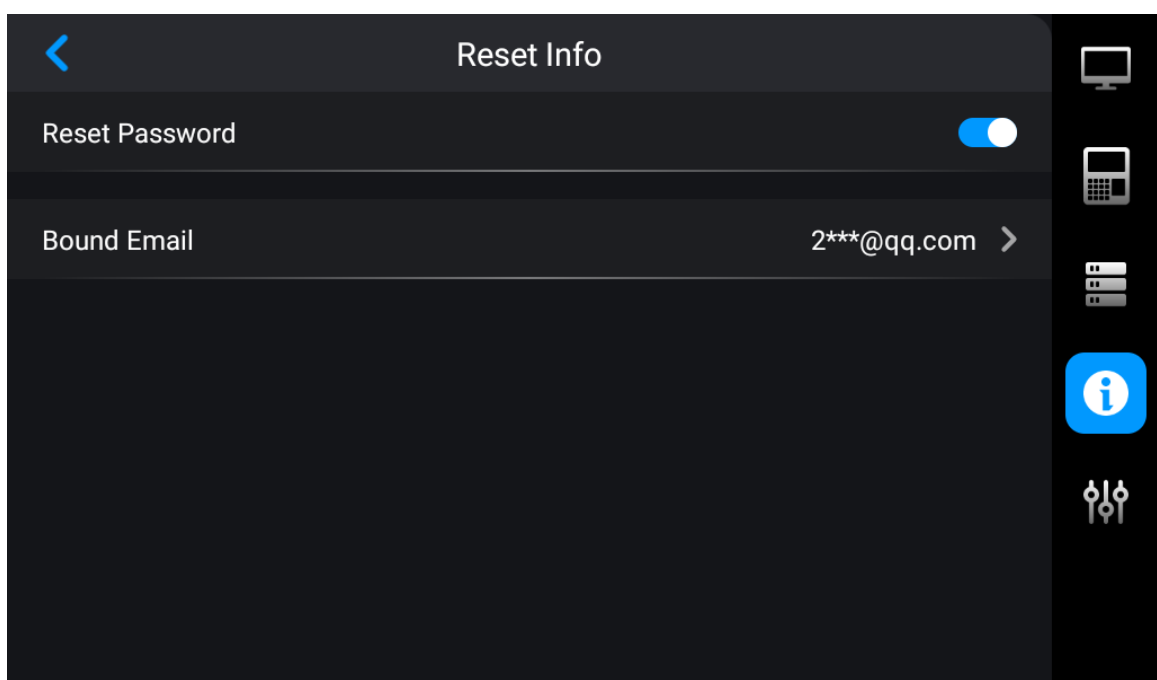
Procedure

Step 1 On the home screen, select **Setting** >  > **Project Settings**.

Step 2 Enter the password, and then tap **OK**.

Step 3 Tap , and then configure the functions.

Figure 3-12 Debug and factory defaults

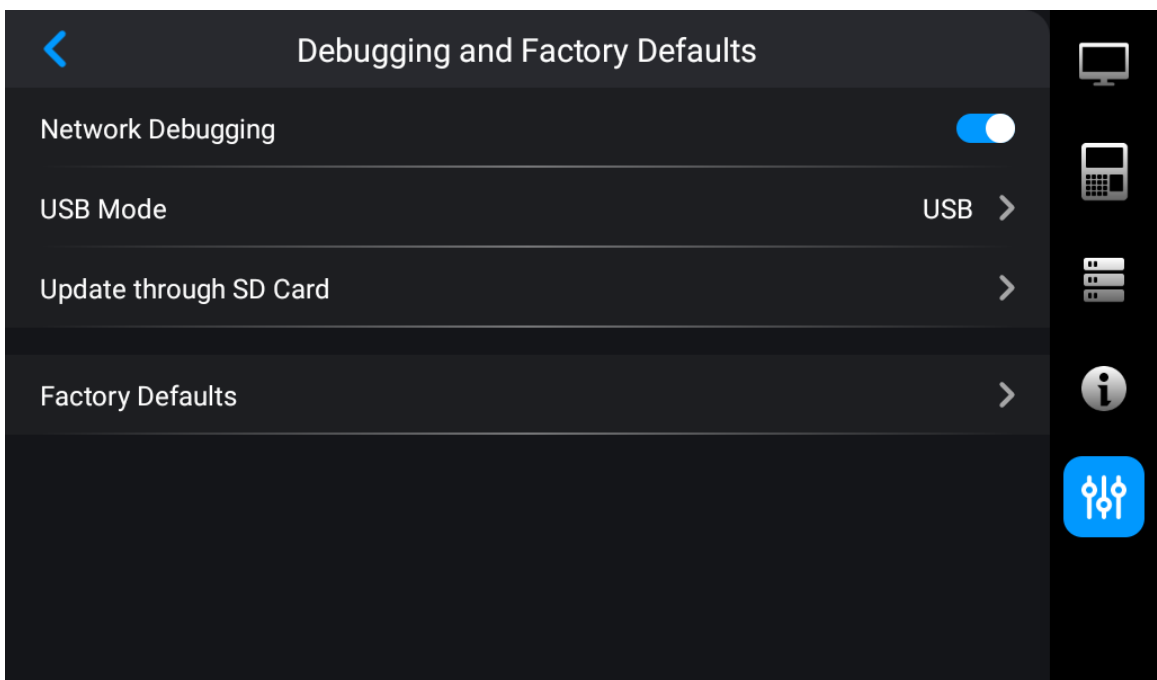



Table 3-7 Parameters description

Parameter	Description
Network Debugging	Only debugged and used by administrators.
USB Mode	<ul style="list-style-type: none">• USB: Administrators debug VTS through the USB port.• OTG: Administrators transmit the data with VTS through the OTG port.
Update through SD Card	Put the update files into the SD card. Update through the SD card that you plugged into VTS. The update file name must be update.zip .
Factory Defaults	VTS clears all information except the IP address, and then it restarts after factory defaults.

3.1.8 Commissioning

3.1.8.1 Call

Call VTH

On the home screen of VTS, tap **Phone**, enter the number of VTH, and then tap .

If you use the gooseneck to talk, the recommended distance is between 5 cm to 10 cm.

Figure 3-13 Dial

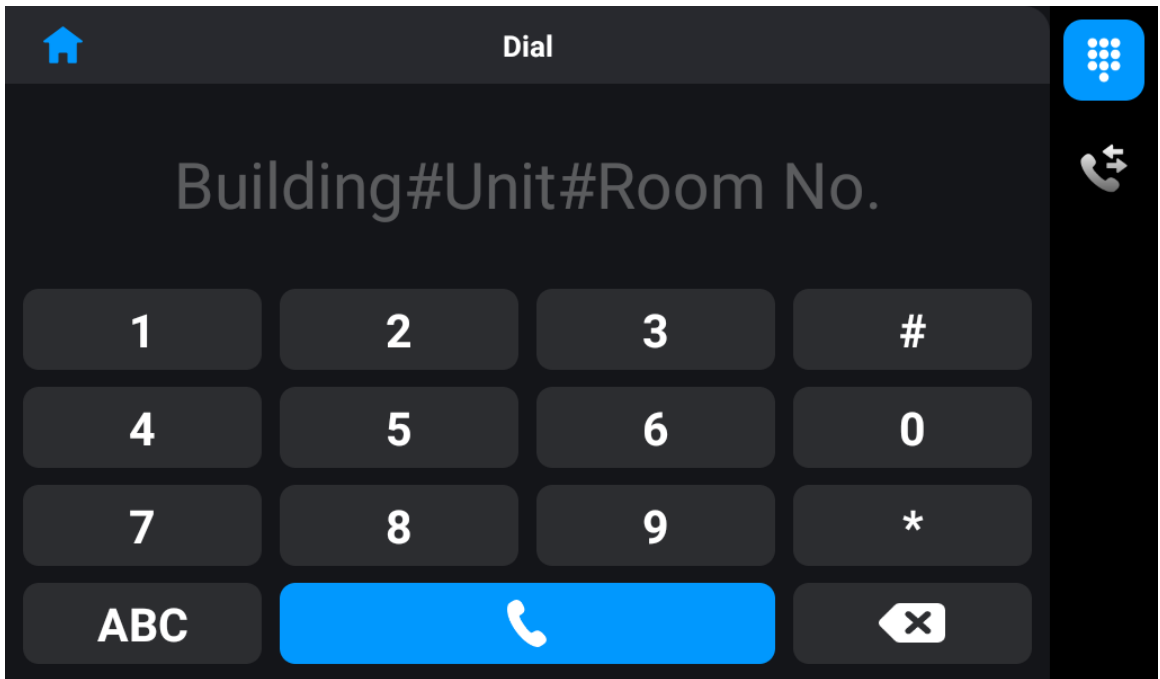

Figure 3-14 Call VTH

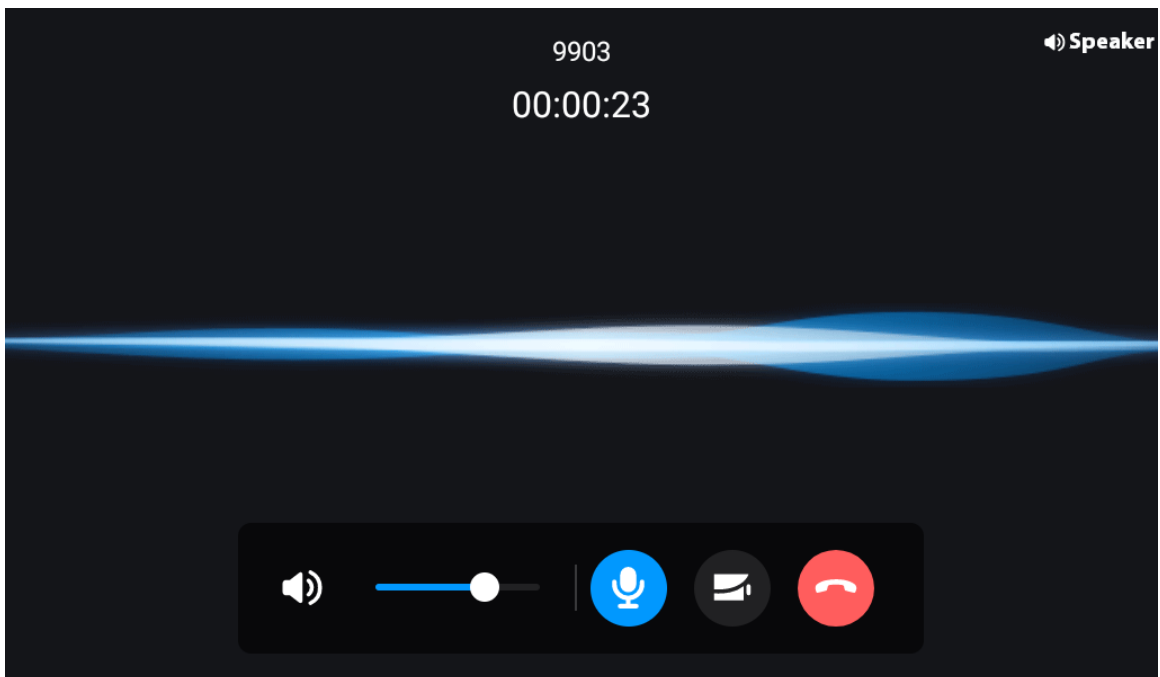







Table 3-8 Icons description

Icon	Description
	Adjust the volume of the speaker during the call.
	Turn on or turn off speech input during the call.
	Tap it to convert to IPC video image during the call.
	Tap it to hang up the call.

Call history

On the home screen of VTS, tap **Phone**, and then tap  to check all calls and missed calls.



- Tap the call on call history list to call back.
- : Check the snapshot files of the call.
- : Check the video files of the call.

Figure 3-15 Call history



3.1.8.2 Checking the Information

Video files

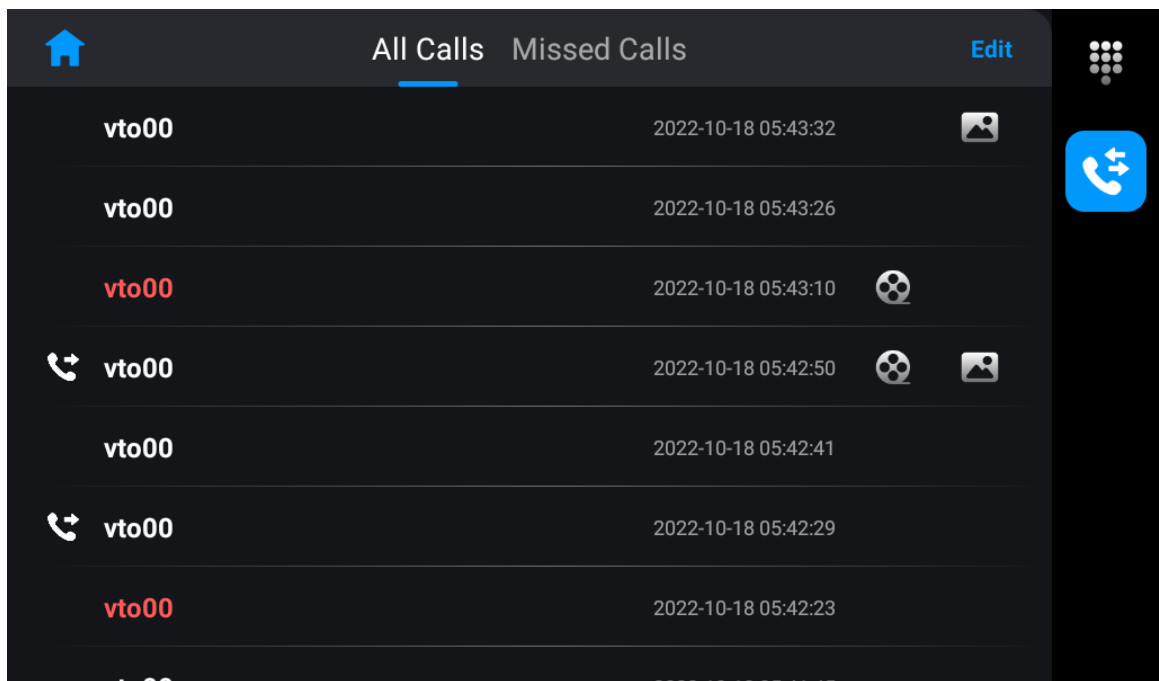
Check or delete the video files that VTS recorded in monitoring or in the call.

Figure 3-16 Video files

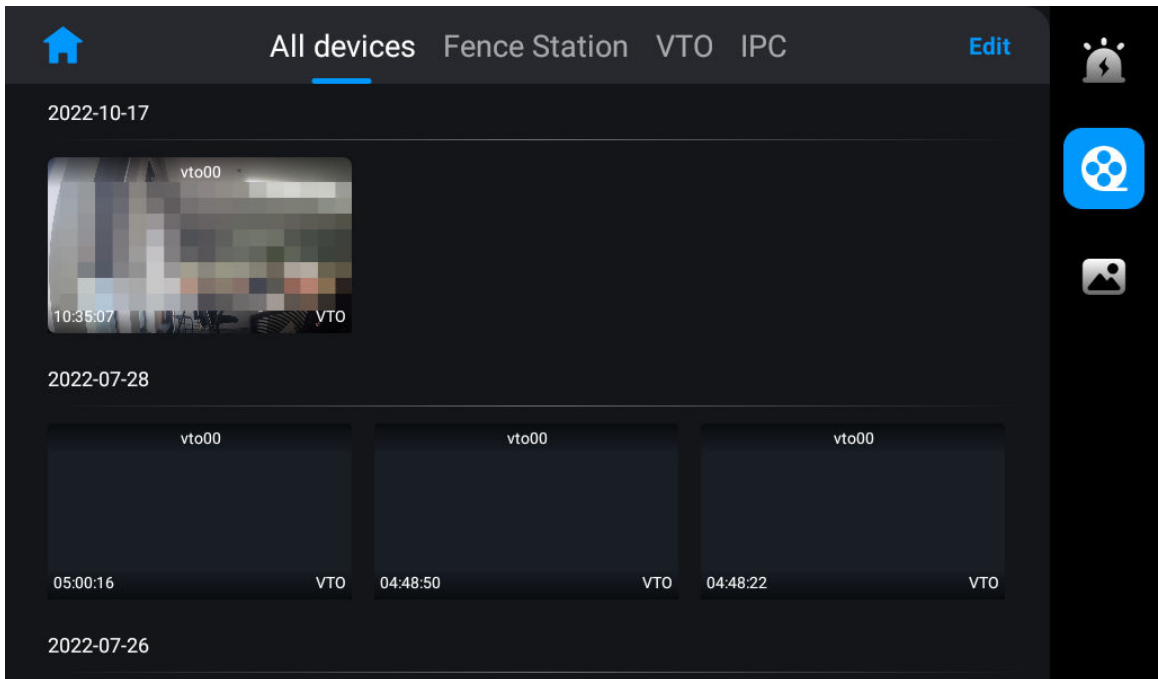

Snapshot files

Check or delete the snapshot files that VTS recorded in monitoring or in the call.

Figure 3-17 Snapshot files

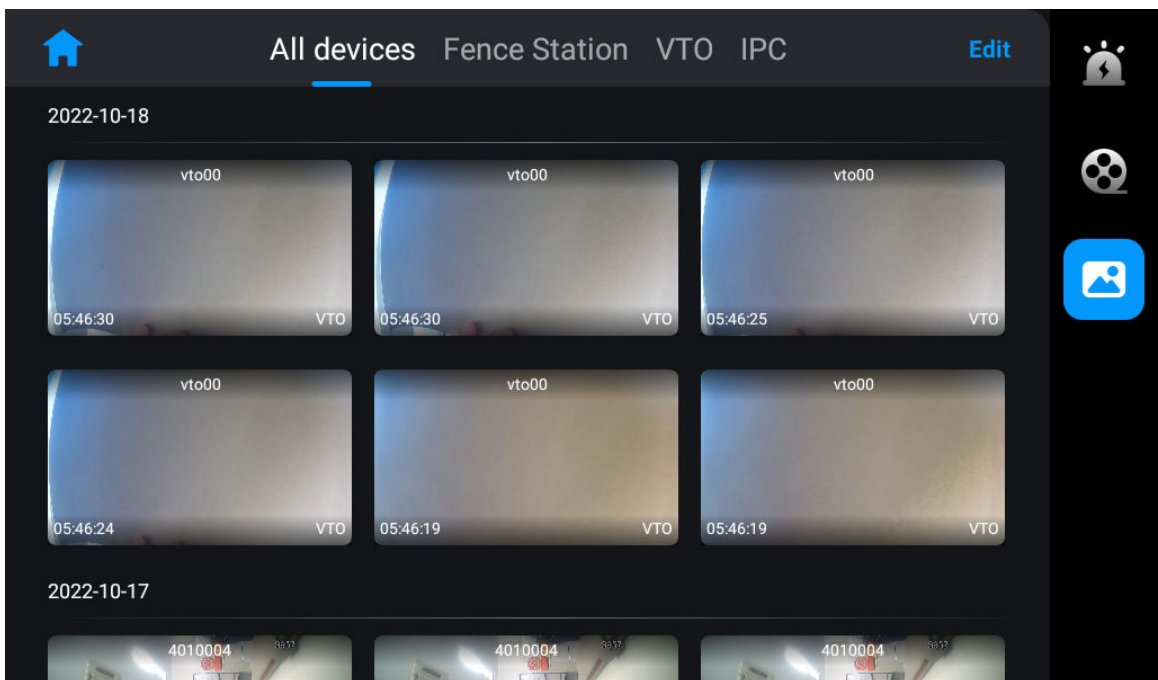

3.1.8.3 Monitoring

Monitor VTO, fence station or IPC on VTS. The operations of monitoring IPC or fence stations are the same with the operations of monitoring VTO. This section uses monitoring VTO as an example.

Prerequisites

Make sure that you have added VTO, fence station or IPC before you monitor them. For details, see "3.1.7.3 Adding Devices".

Procedure

Step 1 On the home screen of VTS, tap **Monitor**.

Step 2 Tap the icon of VTO to monitor.

Figure 3-18 Select VTO

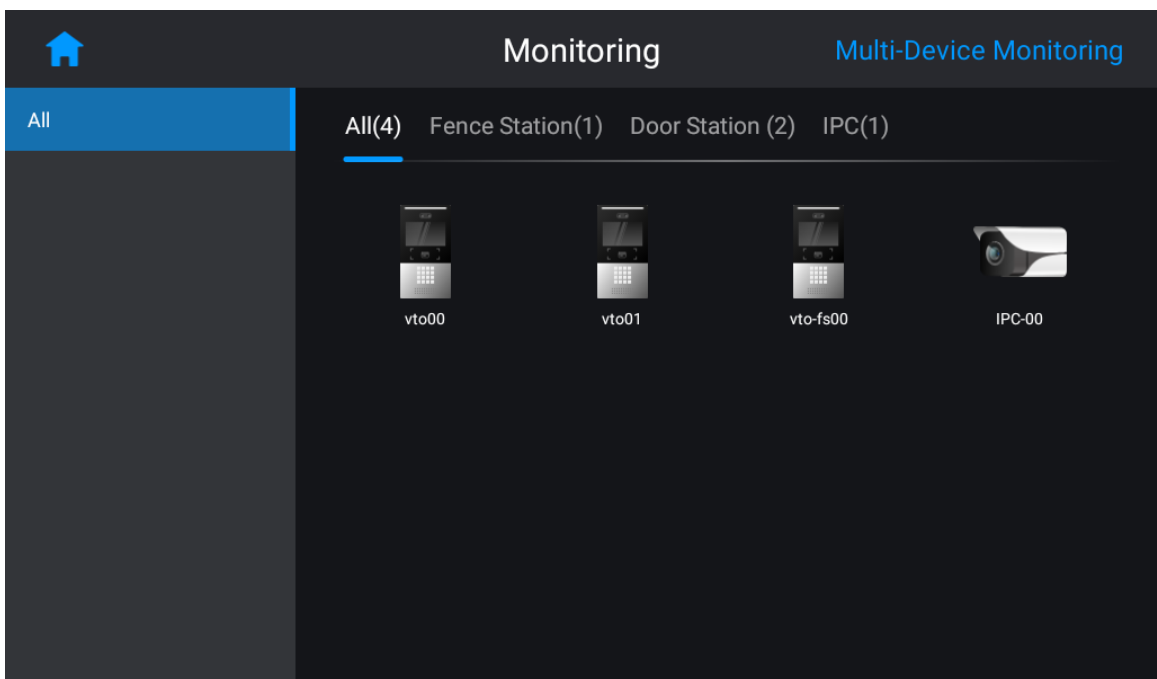

Step 3 Check the monitoring image.

Figure 3-19 Monitoring image

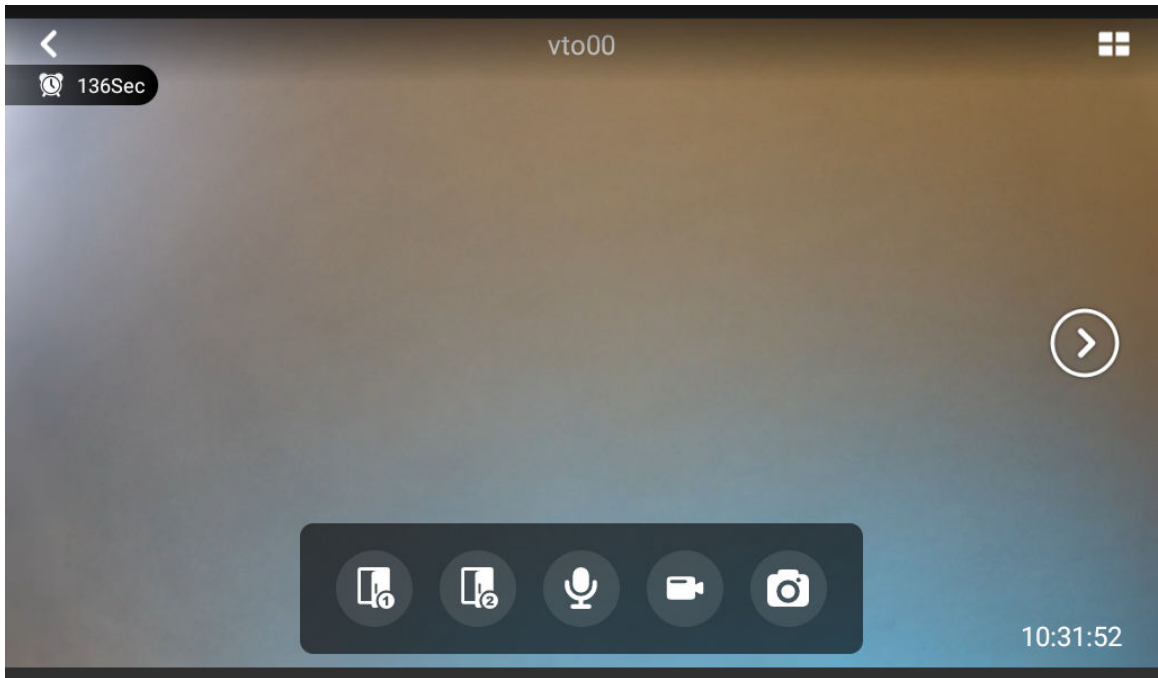









Table 3-9 Monitoring image description

Icon	Description
	Tap to view the monitoring image in 4 windows.
	Tap to convert to monitor other VTOs if VTS connects more than one VTO.
	Remotely unlock VTO.
	
	Call VTO and VTO directly receive the call without taping any icon.
	Tap to start manual recording.
	Tap to manually take snapshots.

3.2 Operations on Webpage

3.2.1 Logging in to the Webpage

Procedure

- Step 1 Enter the IP address of VTS in a browser, and then press the Enter key.

Step 2 Enter the username and password.

Figure 3-20 Log in to the webpage

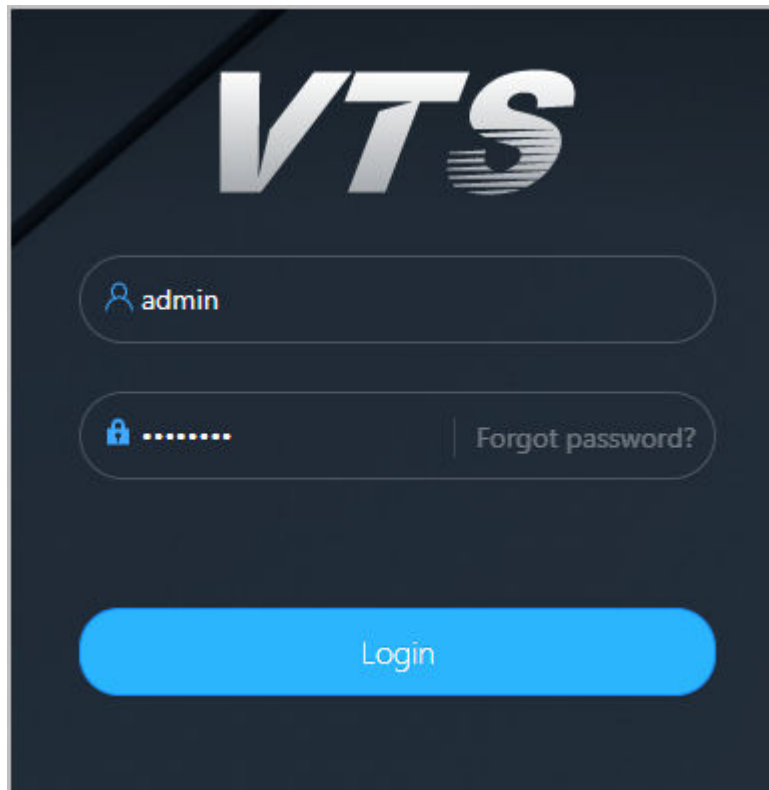

- The default username of administrator is **admin**. The default password is the password that you configured during initialization. We recommend you change the password on a regular basis.
- If you forget the password, click **Forgot password?** to reset the password. For details, see "3.2.2 Resetting Password".

Step 3 Click **Login**.

3.2.2 Resetting Password

Reset password through the e-mail address that you bound if you forget the password.

Procedure

Step 1 On the login page, click **Forgot Password?**

Step 2 Click **OK** on the pop-up window.

Step 3 Scan the QR code on the page, and then get the security code.



- Scan the same QR code, you can get at most 2 security codes. If you need to get the security code again, refresh the QR code page.
- Receive the security code in e-mail. Use the security code in 24 hours to reset the password, otherwise the security code is invalid.
- The account will be locked for 5 minutes if you enter the wrong security code 5 times in a row.

Figure 3-21 Get the security code

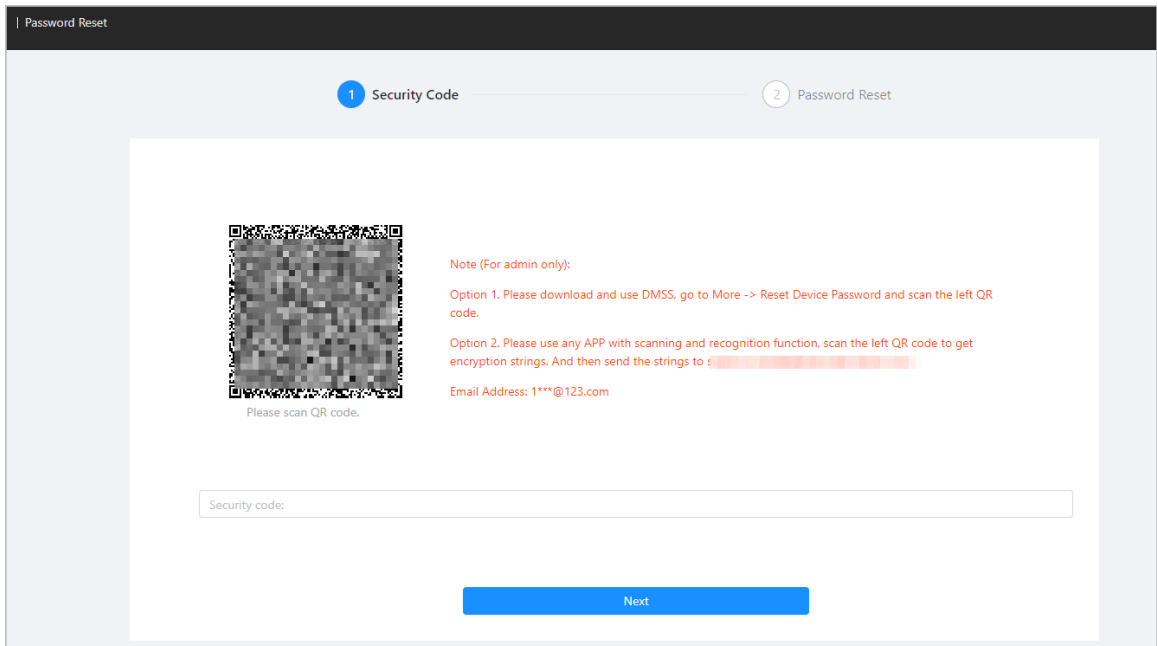

Step 4 Enter the security code you received in the **Security code** text box.

Step 5 Click **Next**.

Step 6 Reset new password and confirm the new password.

The password must consist of 8 to 32 non-blank characters and contain at least two types of characters among number, letter and common character (excluding space, ', ", ;, ;, &).

Step 7 Click **OK** to reset password.

3.2.3 Home Page Introduction

The system automatically goes to the home page after you log in.

Figure 3-22 Home page

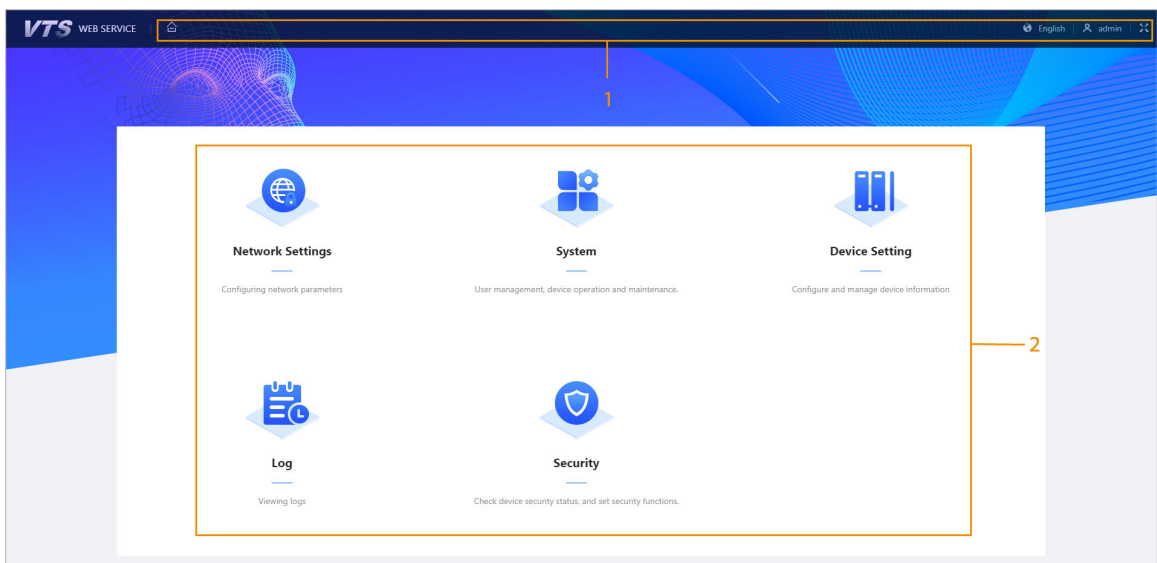





Table 3-10 Home page description

No.	Parameter	Description	
1	Navigation Bar		Go to the home page.
			<ul style="list-style-type: none"> • Click the icon. Select Restart to restart VTS. • Click the icon. Select Logout to log out the account.
			Open the window in a full screen mode.
2	Function Menu	Functions configuration menu of VTS.	

3.2.4 Configuring Network

3.2.4.1 Configuring TCP/IP

Procedure

- Step 1 Log in to the webpage of the device.
- Step 2 Select **Network Settings** > **TCP/IP**.
- Step 3 Configure the parameters.

Figure 3-23 Configure the parameters

The screenshot shows a network configuration form with the following fields and values:

- NIC:** A dropdown menu showing "NIC 1".
- Mode:** Radio buttons for "Static" (selected) and "DHCP".
- MAC Address:** A field with 12 greyed-out characters.
- IP Version:** A dropdown menu showing "IPv4".
- IP Address:** A field with 4 greyed-out octets.
- Subnet Mask:** A field with 4 greyed-out octets.
- Default Gateway:** A field with 4 greyed-out octets.
- Preferred DNS:** A field with 4 greyed-out octets.
- Alternate DNS:** A field with 4 greyed-out octets.
- MTU:** A text input field containing "1500".

At the bottom of the form are three buttons: "Apply" (blue), "Refresh", and "Default".

Table 3-11 Parameters description

Parameter	Description
Mode	<ul style="list-style-type: none"> • Static: Manually configure IP, Subnet Mask and Default Gateway. Click Apply and the webpage automatically goes to the login page of the IP that you configured. • DHCP (Dynamic Host Configuration Protocol): Select DHCP if there is a DHCP server. The device automatically gets a dynamic IP address.
MAC Address	MAC (Media Access Control) address of the device.
IP Version	Select IPv4 .
IP Address	If you select Static in Mode , enter the IP address, subnet mask and default gateway according to the network planning.
Subnet Mask	
Default Gateway	<ul style="list-style-type: none"> • There is no subnet mask in IPv6 version. • IP address and default gateway should be on the same network segment.
Preferred DNS	IP address of DNS server.
Alternate DNS	Alternate IP address of DNS server.

Step 4 Click **Apply**.

3.2.4.2 Configuring SIP Server

Configure the parameters of SIP server. Connect to VTO through SIP agreement to achieve video intercom.

Procedure

- Step 1 Log in to the webpage of VTS.
- Step 2 Select **Network Settings** > **SIP Server**.
- Step 3 Configure the parameters.

Figure 3-24 SIP server parameters

The screenshot displays the SIP Server configuration page. At the top, there is a toggle switch labeled 'SIP Server' which is currently turned off. Below this, there are several input fields: 'IP Address' with the value '192.168.1.1', 'Port' with the value '5060', 'Username' with the value '101', 'Password' which is masked with six dots and has an eye icon to toggle visibility, and 'SIP Domain' with the value 'VDP'. At the bottom of the form, there are three buttons: a blue 'Apply' button, a 'Refresh' button, and a 'Default' button.

Table 3-12 Parameters description

Parameter	Description
IP Address	IP address of SIP server.
Port	Network port number of SIP server. <ul style="list-style-type: none">● VTO as the SIP server: 5060.● The platform as the SIP server: 5080.
Username	Default.
Password	Default.
SIP Domain	Keep consistent with the SIP server. Domain name is VDP by default.

Step 4 Tap **Save**.

3.2.4.3 Configuring Basic Services

Turn on the protocol as needed when connected VTS with the third-party platform.
 Log in to the webpage of VTS, and then select **Network Settings** > **Basic Services**.

Figure 3-25 Basic services

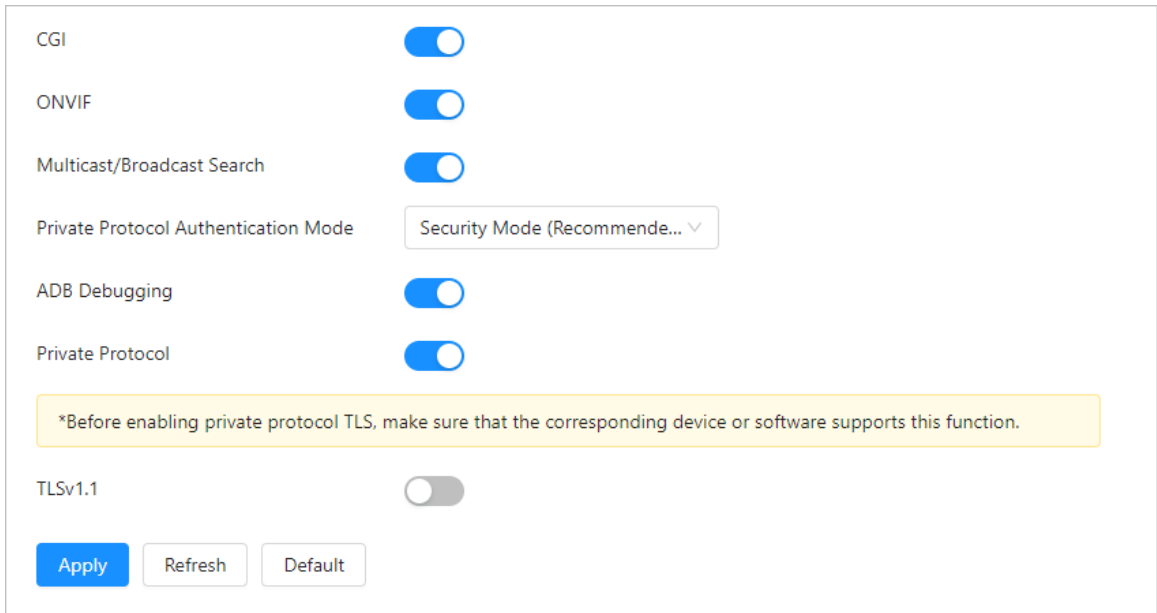



Table 3-13 Description of basic services

Service	Description
CGI	Common Gateway Interface (CGI) offers a standard protocol for web servers to execute programs similarly to console applications running on a server that dynamically generates web pages. If enabled, CGI commands can be used. The CGI is enabled by default.
ONVIF	Enable other devices to pull video stream of the device through the ONVIF protocol.
Multicast/Broadcast Search	Enable this function, and then when multiple users are previewing the device video image simultaneously through network, they can find your device with multicast/broadcast protocol.
Private Protocol Authentication Mode	<ul style="list-style-type: none"> ● Security Mode (Recommended) : The mode does not support logging in with Digest, DES and plain text authentication. ● Compatibility Mode : The mode supports logging in with Digest, DES and plain text authentication.
ADB Debugging	This function is only available for debugging personnel.
Private Protocol	If enabled, the platform can access to the device with private protocol.
TLSv1.1	 There is security risk if you enable TLSv1.1 .

3.2.4.4 Configuring Auto Registration

VTS automatically register on the server, and report its IP address to designated server

Procedure

- Step 1 Log in to the webpage of VTS.
- Step 2 Select **Network Settings** > **Auto Registration**.
- Step 3 Turn on **Enable**. Enter the server address, port number and sub-device ID.

Figure 3-26 Auto registration

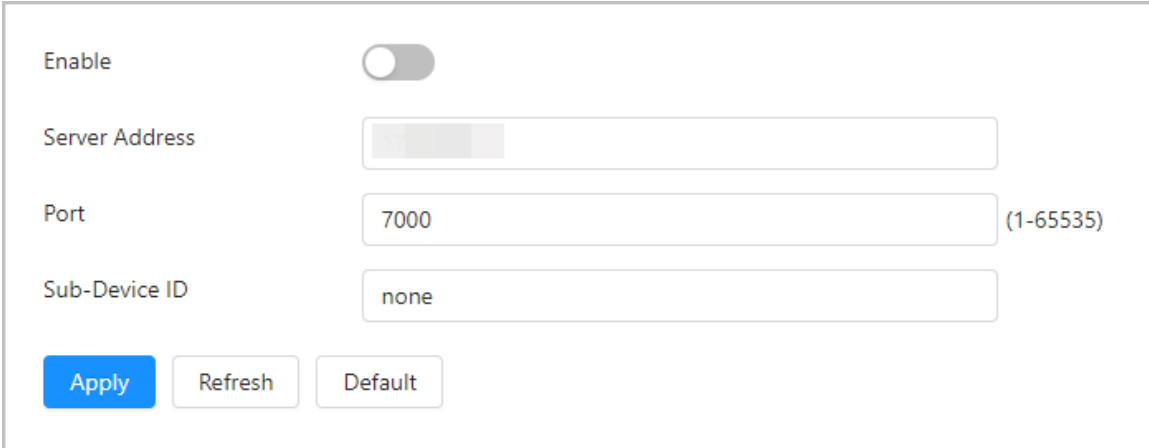

Table 3-14 Parameters description

Parameter	Description
Server Address	IP address or domain name of the server that is needed in registration.
Port	Port number that the server automatically registers.
Sub-Device ID	The server distributes an ID for the device. Keep consistent with the ID registered on the server.

3.2.5 System Management

3.2.5.1 Configuring Basic Parameters of VTS

Configure the number and other functions of VTS.

Procedure

- Step 1 Log in to the webpage of VTS.
- Step 2 Select **System** > **General**.
- Step 3 Configure the parameters.
 - You can configure the number from 101 to 999.
 - Turn on the **Building No.** and **Unit No.** as needed.

Figure 3-27 Configure basic parameters

Device No.

Building No.

Unit No.

Step 4 Click **Apply**.

3.2.5.2 Configuring Video Parameters

Background Information



Video is available on select models.

Procedure

- Step 1 Log in to the webpage of VTS.
- Step 2 Select **System** > **Video**.
- Step 3 Configure the parameters.

Figure 3-28 Video parameters

Video Standard

Main Stream

Compression

Resolution

Frame Rate (FPS)

Sub Stream

Compression

Resolution

Frame Rate (FPS)

Table 3-15 Parameters description

Parameter		Description
Video Standard		<ul style="list-style-type: none"> ● PAL: The default stream frame rate is 25 fps. ● NTSC: The default stream frame rate is 30 fps.
Main Stream	Compression	Select the compression mode depending on the actual bandwidth. <ul style="list-style-type: none"> ● H.264: Main profile compression. ● H.265: Main profile compression occupies smaller bandwidth than H.264 in the same image quality.
	Resolution	Select the resolution as needed.
	Frame Rate (FPS)	The number of frames that appears within a second. Higher FPS refers to more vivid and smoother image.
Sub Stream	Compression	Select the compression mode depending on the actual bandwidth. <ul style="list-style-type: none"> ● H.264: Main profile compression. ● H.265: Main profile compression occupies smaller bandwidth than H.264 in the same image quality.
	Resolution	Select the resolution as needed.
	Frame Rate (FPS)	The number of frames that appears within a second. Higher FPS refers to more vivid and smoother image.

3.2.5.3 Account Management

Add user and edit user information depending on different protocols.

3.2.5.3.1 Adding User

You are admin user by default. You can add users. Newly added users can only log in to the webpage of VTS.

Procedure

- Step 1 Log in to the webpage of VTS.
- Step 2 Select **System** > **Account**.
- Step 3 Click **Add**.
- Step 4 Configure the parameters.

Figure 3-29 Add users

Table 3-16 Description of user parameters

Parameter	Description
Username	User's unique identification. You cannot use existing user name. The max. length of the username is 31 characters which consist of number, letter, underline, dash, dot and @.
Password	The password must consist of 8–32 non-blank characters and contain at least two types of number, letter, and special characters (excluding ' " ; : &).
Confirm Password	
Remarks	User-defined.

Step 5 Click **OK**.

The newly added user is displayed in the user list.

Related Operations

- Modify user information. Click  to edit password, group of the added user.



For admin account, you can only edit the password.

- Delete user. Click  to delete the added user.



The admin account cannot be deleted.

3.2.5.3.2 Resetting Password

Reset password through the e-mail address that you bound if you forget the password.

Procedure

Step 1 Log in to the webpage of VTS.

Step 2 Select **System** > **Account**.

Step 3 Click to enable **Password Reset**.

Step 4 Enter the email address and configure the password expiry period.

Password expires in x days: User-defined. If you select **Never**, the system does not remind you to change the password.

Figure 3-30 Reset password

Password Reset

Enable

If you forgot the password, you can receive security codes through the email address left in advance to reset the password.

Email Address

Password Expires in Days

Step 5 Click **Apply**.

3.2.5.3.3 Adding ONVIF User

You can add, delete ONVIF user, and change their passwords. The default ONVIF user is admin.

Procedure

Step 1 Log in to the webpage of VTS.

Step 2 Select **System** > **Account** > **ONVIF User**.

Step 3 Click **Add**.

Step 4 Configure the parameters.

Figure 3-31 Add ONVIF user

Table 3-17 Description of ONVIF user parameters

parameter	Description
Username	User's unique identification. You cannot use existed username. The max length of the user or group name is 31 characters which consist of number, letter, underline, dash, dot and @.
Password	The password must consist of 8–32 non-blank characters and contain at least two types of number, letter, and special characters (excluding ' " ; : &).
Confirm Password	
Group	The group that users belong to. Each group has different authorities.

Step 5 Click **OK**.

The newly added user displays in the username list.

Related Operations

- Modify user information. Click  to edit password, group of the added user.



For admin account, you can only edit the password.

- Delete user. Click  to delete the added user.



The admin account cannot be deleted.

3.2.5.4 Viewing Online User

Log in to the webpage of VTS. Select **System** > **Online User** to view the current users logging into the web. You can view username, IP address and login time.

Figure 3-32 Online user

No.	Username	IP Address	User Login Time
1	admin	10.33.123.115	2022-11-07 07:06:23

3.2.5.5 Configuring Time

You can configure date, time zone, and NTP (Network Time Protocol) server.

Procedure

- Step 1 Log in to the webpage of VTS.
- Step 2 Select **System** > **Time**.
- Step 3 Configure the parameters.

Figure 3-33 Configure time

Time and Time Zone



Date :
2022-11-07 Monday

Time :
07:27:01

Time Manual Settings NTP

Time

Time Zone

Table 3-18 Description of date and time parameters

Parameter		Description
Time and Time Zone	Time	Select Manual Settings or NTP .

Parameter		Description
	Time	If you select Manual Settings , configure the system time manually. Click Sync PC , and the system time changes to the PC time.
	Server	If you select NTP , the system then syncs time with the internet server in real time.
	Port	
	Interval	You can also enter the IP address, port, and interval of a PC running NTP server to use NTP.
	Time Zone	Configure the time zone that VTS is at.

Step 4 Click **Apply**.

3.2.5.6 Configuring Maintenance

Configure the auto restarting time so that the VTS can restart automatically to improve the running speed.

Procedure

- Step 1 Log in to the webpage of VTS.
- Step 2 Select **System** > **Maintenance**.
- Step 3 Configure **Restart Time**.

Figure 3-34 Maintenance



The default restart time is 2 o'clock every Tuesday.

Step 4 Click **Apply**.

Related Operations

Click **Restart** to restart VTS.

3.2.5.7 Configuration Management

Log in to the webpage of VTS. Select **System** > **Config**.

Figure 3-35 Configuration management

The screenshot shows a web interface for configuration management. It is divided into two main sections: 'Config' and 'Default'.
The 'Config' section contains a button labeled 'Export Configuration File'. Below it, there is a 'File' label, an empty text input field, a button labeled 'Please select file.', and a button labeled 'Import File'. A yellow warning banner below the input field states: 'Imported configuration will overwrite previous configuration.'
The 'Default' section contains two buttons: 'Factory Defaults' and 'Restore to Default (Except for User Info and Logs)'.

3.2.5.7.1 Import/Export Configuration File

Import or export the system configuration file. Use configuration backup file when many devices need the same parameters configuration.

Export configuration file

Click **Export Configuration File** to export the system configuration file to local storage.



The export file excludes IP information.

Import configuration file

1. Click **Please select file.** to select local configuration file.
2. Click **Import File.**



Supports importing the configuration file to devices of the same mode.

3.2.5.7.2 Factory Default



This function will restore the device to default configuration or factory settings. The data will be lost. Operate it carefully.

- **Factory Defaults** : All the configurations are restored to factory settings. Device information and user information will be cleared.
- **Restore to Default (Except for User Info and Logs)** : All the configurations except user information and logs are recovered to default.

3.2.5.8 Updating

Background Information



- Do not power off the device or the network, restart or turn off the device.
- If wrong upgrade file has been used, restart the device; otherwise some functions might not work properly.
- Upgrade has potential security risks. Operate it carefully.

Procedure

Step 1 Log in to the webpage of VTS.

Step 2 Select **System** > **Update**.

Step 3 Select the updating mode as needed.

- File update
 1. Click **Browse**, and then upload updating file. The updating file should be a .bin file.
 2. Click **Update**.

- Online update

Get the new version through auto check or manual check. Click **Update Now**.

- ◇ Auto check: Click **Auto Check**. The system automatically checks the new version once every day, and remind you if there is a new version.



We will collect IP address, device name, hardware version, device serial number and other device information to inform you update in time. The information collected are only used for verification of the device legitimacy and for notification of the updating.

- ◇ Manual check: Click **Manual Check** to manually check the new version of the system.

3.2.5.9 Viewing Version

Log in to the webpage. Select **System** > **Version** to view the model, serial number of the device, system version and hardware version and other version information.

3.2.5.10 Viewing Legal Information

Log in to the webpage. Select **System** > **Legal Info** to view the open source software notice and other legal information.

3.2.6 Device Management

3.2.6.1 Configuring IPC

Supports connecting with no more than 32 IPC. VTS monitors the devices in an integrated way.

Procedure

Step 1 Log in to the webpage of VTS.

Step 2 Select **Device Setting** > **IPC Info**.

Step 3 Click  to configure the parameters of IPC.

Figure 3-36 Configure IPC

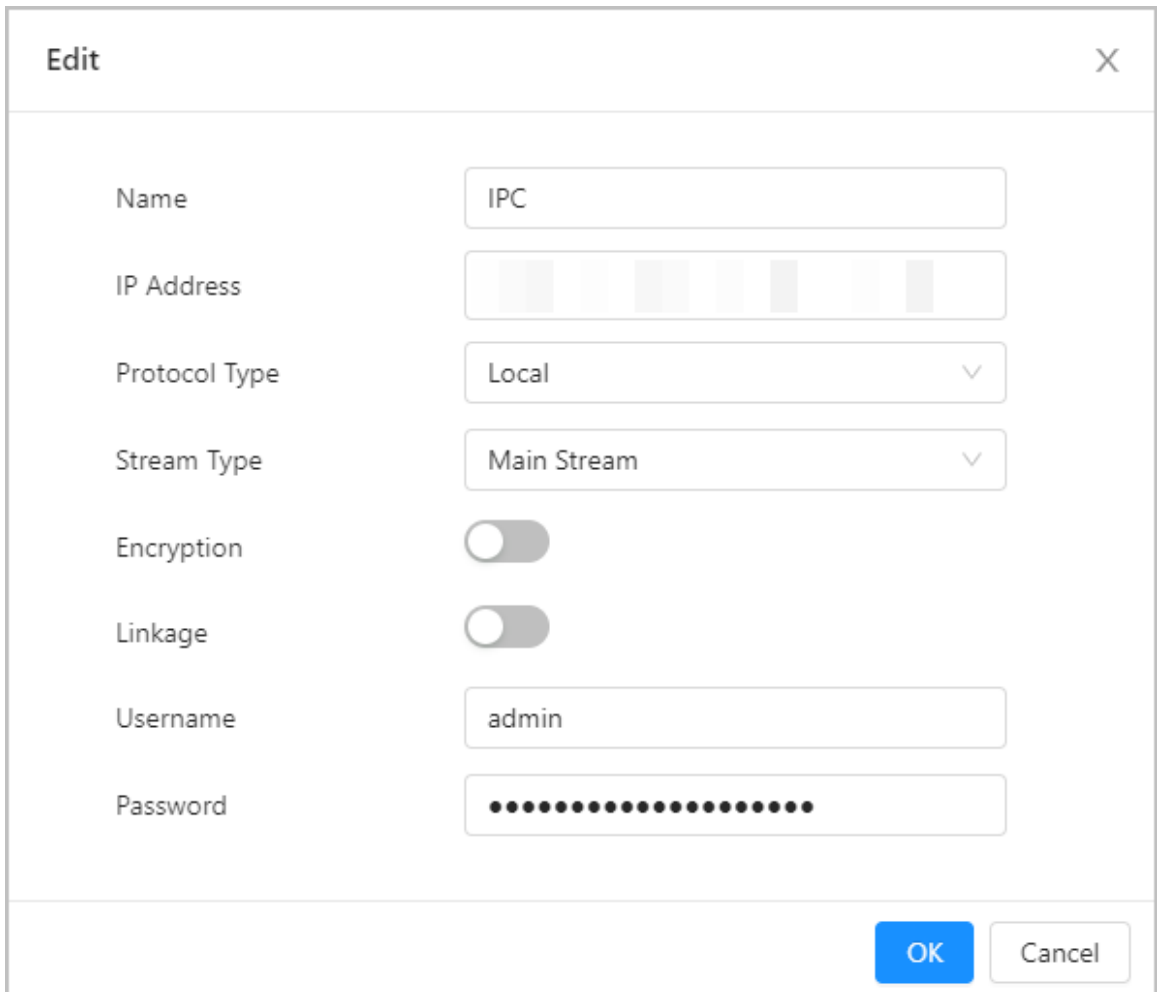

Table 3-19 Description of IPC parameters

Parameter	Description
Name	User-defined. You can configure the name that distinguishes the device.
IP Address	IP address of the added IPC.
Protocol Type	Select local protocol or ONVIF protocol depending on the IPC that you added.
Stream Type	Select main stream or sub stream. <ul style="list-style-type: none">● Main stream: Large stream has high definition, occupying a large bandwidth. Used for local storage.● Sub stream: Smooth image occupies a small bandwidth. Used for low-bandwidth network transmission.
Encryption	Turn on encryption. The video is transferred in encryption.
Linkage	VTH supports displaying the image of connected IPC when VTS calls VTH if you turn on this function.

Parameter	Description
Username	The username and password of the IPC that you added.
Password	

3.2.6.2 Adding VTO or Fence Station

Procedure

- Step 1 Log in to the webpage of VTS.
- Step 2 Select **Device Setting** > **Device Setting** > **All**.
- Step 3 Click **Add**.
- Step 4 Configure the parameters.

You can select door station or fence station.

Figure 3-37 Add door station of fence station

- Step 5 Click **OK**.

Related Operations

- Export: Export the device information.
- Import: Import the file to the current device to add devices in batches. The file must be exported from the device in the same model.

3.2.7 Log

3.2.7.1 Viewing System Log

Procedure









- Step 1 Log in to the webpage of VTS.
- Step 2 Select **Log > Log**.
- Step 3 Select the log type, configure the time range, and then click .
- Click **Export** to export the log to the local computer. If you select **Encrypt Log Backup**, enter the encryption password, and then export the log.
 - Click  to view the log information.

Figure 3-38 System log

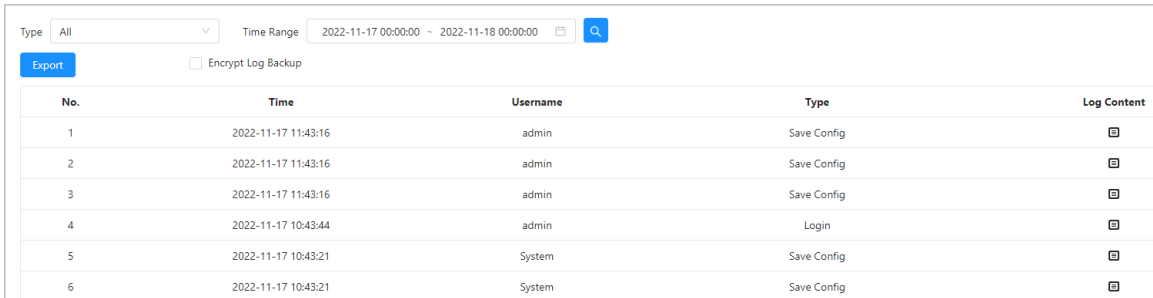

The screenshot shows a web interface for viewing system logs. At the top, there is a 'Type' dropdown menu set to 'All', a 'Time Range' field with the date '2022-11-17 00:00:00 - 2022-11-18 00:00:00', and a search icon. Below this, there is an 'Export' button and a checkbox for 'Encrypt Log Backup'. The main part of the interface is a table with the following columns: 'No.', 'Time', 'Username', 'Type', and 'Log Content'. The table contains six rows of log entries.

No.	Time	Username	Type	Log Content
1	2022-11-17 11:43:16	admin	Save Config	
2	2022-11-17 11:43:16	admin	Save Config	
3	2022-11-17 11:43:16	admin	Save Config	
4	2022-11-17 10:43:44	admin	Login	
5	2022-11-17 10:43:21	System	Save Config	
6	2022-11-17 10:43:21	System	Save Config	

3.2.7.2 Viewing Call History

Procedure

- Step 1 Log in to the webpage of VTS.
- Step 2 Select **Log > Call History**.
- Step 3 (Optional) Click **Export** to export the call history to local computer.

3.2.7.3 Viewing Alarm Log

Procedure

- Step 1 Log in to the webpage of VTS.
- Step 2 Select **Log > Log**.
- Step 3 Select the log type, configure the time range, and then click .

3.2.8 Security

3.2.8.1 Security Status

Detect and check the security status of the device.

Log in to the webpage of VTS. Select **Security > Security Status**. Click **Rescan** to scan the security status of the device.

Figure 3-39 Security status

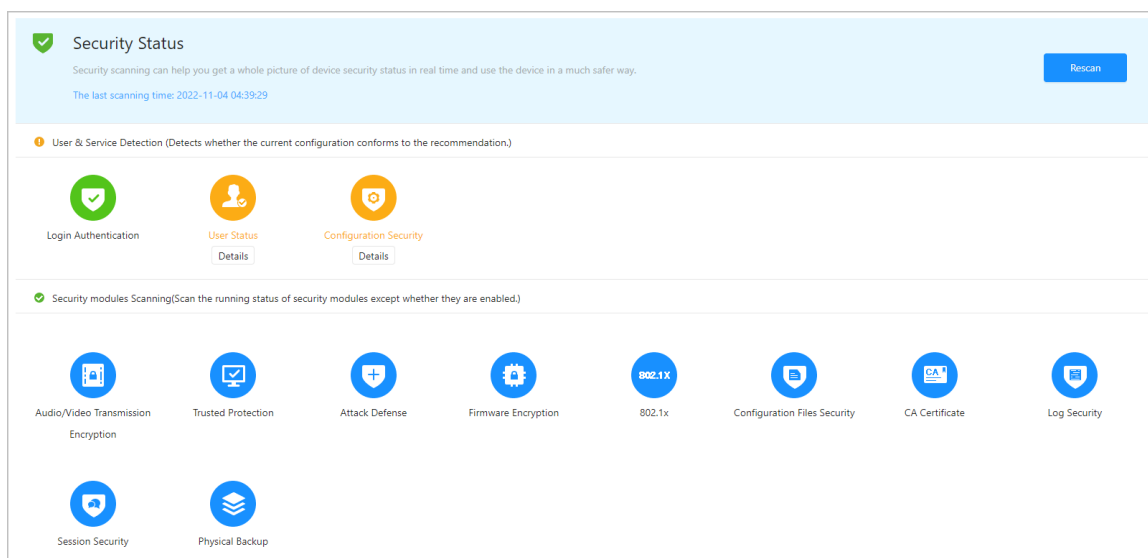

User & Service Detection

- If the configuration of the detection item conforms to the recommendation, the icon is green.
- If the detection item needs to be optimized, the icon is yellow. Click **Details** to view the details of the scanning result. Click **Ignore** to ignore the exception, and it will not be scanned in next scanning.
- If the detection item will not be scanned, the icon is grey. Click **Start Detection** to include the detection item in next scanning.



Hover over the detection item to view the configuration of the current detection.

Security Modules Scanning

Hover over the security module icon to view the operating status.

3.2.8.2 Configuring System Service

Background Information

Create a certificate or upload an authenticated certificate, and then you can log in through HTTPS with your PC. The HTTPS can protect page authenticity on all types of websites, secure accounts, and keep user communications, identity, and web browsing private.



We recommend you enable the HTTPS. Otherwise, the device data may be leaked.

Procedure

- Step 1** Log in to the webpage of VTS.
- Step 2** Select **Security** > **System Service**.
- Step 3** Click to enable HTTPS.
- Step 4** Select the certificate.

If there is no certificate in the list, click **Certificate Management** at the left navigation bar. For details, see "3.2.8.4 Installing Device Certificate".

Figure 3-40 HTTPS

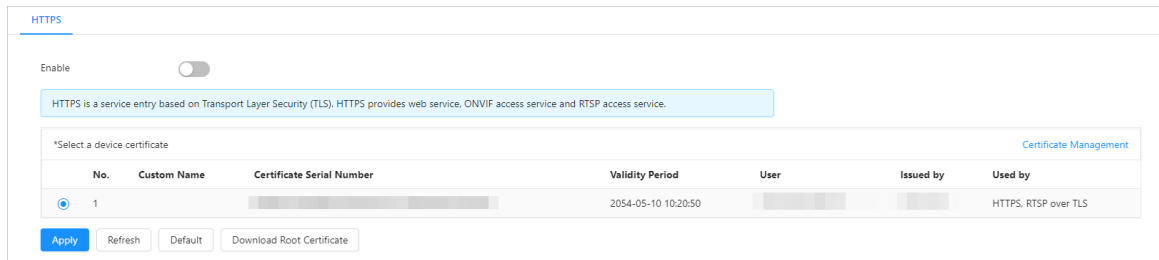

Step 5 Click **Apply**.

Results

Enter `https://IPaddress: https port` in the browser.

- If you have already installed the certificate, the normal login page will be displayed.
- If you have not installed the certificate, the browser displays a certificate error message.

3.2.8.3 Attack Defense

3.2.8.3.1 Configuring Firewall

Configure firewall to limit access to the device.

Procedure

- Step 1** Log in to the webpage of VTS.
- Step 2** Select **Security** > **Attack Defense** > **Firewall**.
- Step 3** Click to enable the firewall function.

Figure 3-41 Firewall

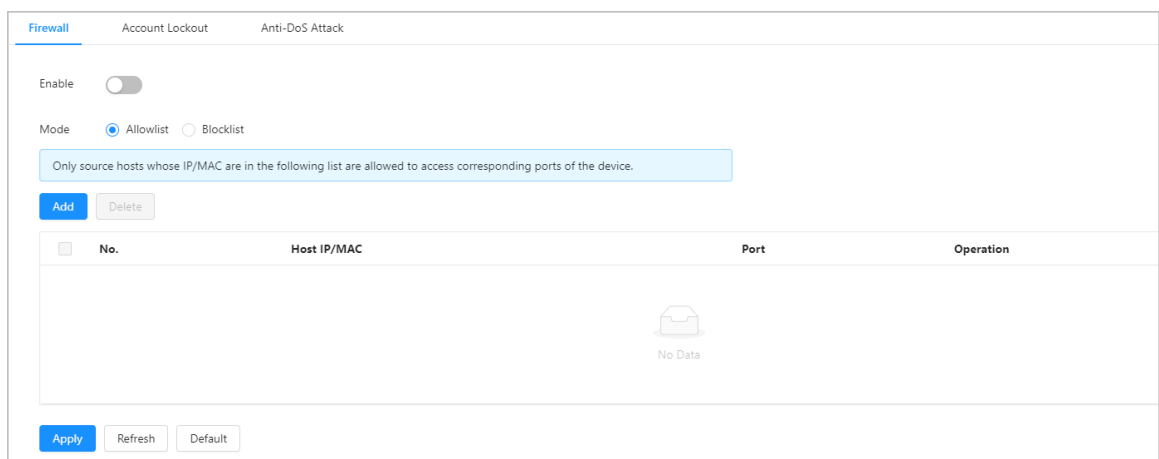

Step 4 Select **Allowlist** or **Blocklist** as the mode.

- **Allowlist:** Only when the IP/MAC address of your PC is in the allowlist, can you access VTS. Ports are the same.
- **Blocklist:** When the IP/MAC address of your PC is in the blocklist, you cannot access VTS. Ports are the same.

Step 5 Click **Add** to add the host IP/MAC address to **Allowlist** or **Blocklist**, and then click **OK**.

Figure 3-42 Add the address



The screenshot shows a dialog box titled "Add" with a close button (X) in the top right corner. The dialog contains the following fields and controls:

- Add Mode:** A dropdown menu with "IP" selected.
- IP Version:** A dropdown menu with "IPv4" selected.
- IP Address:** A field with a dotted pattern for input.
- All Device P...:** A toggle switch that is currently turned off.
- Start Port:** A text input field containing "90" with a range indicator "(1-65535)" below it.
- End Port:** A text input field containing "63000" with a range indicator "(1-65535)" below it.

At the bottom right of the dialog, there are two buttons: a blue "OK" button and a white "Cancel" button with a grey border.

Step 6 Click **Apply**.

Related Operations

- Click  to edit the host information.
- Click  to delete the host information.

3.2.8.3.2 Configuring Account Lockout

If you consecutively enter a wrong password more than the configured value, the account will be locked.

Procedure

- Step 1 Log in to the webpage of VTS.
- Step 2 Select **Security > Attack Defense > Account Lockout**.
- Step 3 Configure the login attempt and lock time for device account and ONVIF user.
 - Login attempt: Upper limit of login attempts. If you consecutively enter a wrong password more than the defined value, the account will be locked.

- Lock time: The period during which you cannot log in after the login attempts reaches upper limit.

Figure 3-43 Account lockout

Firewall **Account Lockout** Anti-DoS Attack

Device Account

Login Attempt 5time(s) ▾

Lock Time 5 min

ONVIF User

Login Attempt 30time(s) ▾

Lock Time 5 min

Apply Refresh Default

Step 4 Click **Apply**.

3.2.8.3.3 Configuring Anti-DoS Attack

You can enable **SYN Flood Attack Defense** and **ICMP Flood Attack Defense** to defend the device against DoS (Denial of Service) attack.

Procedure

- Step 1 Log in to the webpage of VTS.
- Step 2 Select **Security** > **Attack Defense** > **Anti-DoS Attack**.
- Step 3 Select **SYN Flood Attack Defense** or **ICMP Flood Attack Defense** to defend the device against DoS (Denial of Service) attack.

Figure 3-44 Anti-DoS Attack

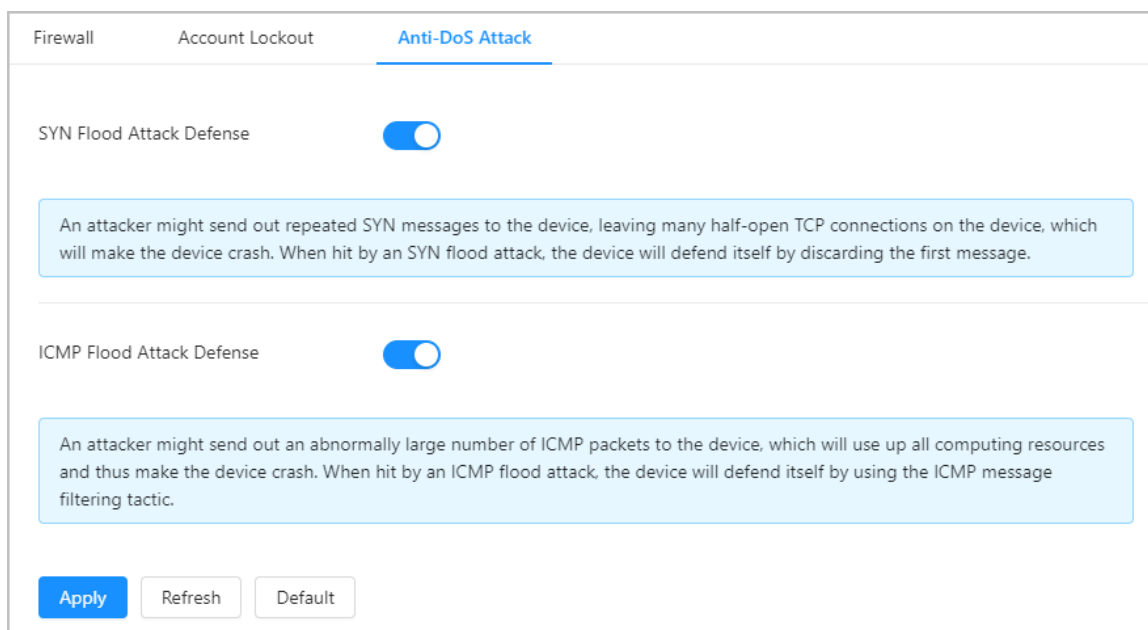

Step 4 Click **Apply**.

3.2.8.4 Installing Device Certificate

Create a certificate or upload an authenticated certificate, for example when you log in through HTTPS with your PC, you need to verify device certificate.

3.2.8.4.1 Creating Certificate

Procedure

- Step 1** Log in to the webpage of VTS.
- Step 2** Select **Security > CA Certificate > Device Certificate**.
- Step 3** Click **Install Device Certificate**.
- Step 4** Select **Create Certificate**, and then click **Next**.
- Step 5** Enter the certificate information.
IP or domain name of the device is automatically entered in **IP/Domain Name**.

Figure 3-45 Certificate Information (1)

Step 2: Fill in certificate information. [X]



Custom Name	test
IP/Domain Name	[blurred]
Organization Unit	test
Organization	test1
Validity Period	200 Days (1~5000)
Region	CN
Province	Zhejiang
City Name	Hangzhou

[Back] [Create and install certificate] [Cancel]

Step 6 Click **Create and install certificate**.

After the certificate is created successfully, you can view the created certificate on the **Device Certificate** page.

Related Operations

- Click **Enter Edit Mode** to edit the custom name of the certificate.
- Click  to download the certificate.
- Click  to delete the certificate.

3.2.8.4.2 Applying for and Importing CA Certificate

Import the third-party CA certificate to the device.

Procedure

- Step 1** Log in to the webpage of VTS.
- Step 2** Select **Security > CA Certificate > Device Certificate**.
- Step 3** Click **Install Device Certificate**.
- Step 4** Select **Apply for CA Certificate and Import (Recommended)**, and then click **Next**.
- Step 5** Enter the certificate information.
IP or domain name of the device is automatically entered in **IP/Domain Name**.

Figure 3-46 Certificate information (2)

The screenshot shows a dialog box titled "Step 2: Fill in certificate information." with a close button (X) in the top right corner. The dialog contains several input fields for certificate information:

- IP/Domain Name: [Redacted]
- Organization Unit: test
- Organization: test1
- Validity Period: 200 Days (1~5000)
- Region: CN
- Province: Zhejiang
- City Name: Hangzhou

At the bottom of the dialog, there are three buttons: "Back", "Create and Download" (highlighted in blue), and "Cancel".

Step 6 Click **Create and Download**.

Save the request file to your PC.

Step 7 Apply for the CA certificate from the third-party certificate authority.

Step 8 Import the signed CA certificate.

1. Save the CA certificate to the PC.
2. Select **Install Device Certificate**, click **Apply for CA Certificate and Import (Recommended)**, and then click **Next**.
3. Click **Browse** to select the signed CA certificate.

Figure 3-47 Import the signed CA certificate



The screenshot shows a dialog box titled "Step 3: Import the signed certificate." with a close button (X) in the top right corner. The dialog contains a "Certificate Path" input field with a "Browse" button next to it. At the bottom of the dialog, there are three buttons: "Recreate", "Import and Install" (highlighted in blue), and "Import Later".

4. Click **Import and Install**.

After the certificate is created successfully, you can view the created certificate on the **Device Certificate** page.

- Click **Recreate** to create the request file again.
- Click **Import Later** to import the certificate next time.

Related Operations

- Click **Enter Edit Mode** to edit the custom name of the certificate.
- Click  to download the certificate.
- Click  to delete the certificate.

3.2.8.4.3 Installing Existing Certificate

Import the existing third-party certificate to the device. When apply for the third-party certificate, you also need to apply for the private key file and private key password.

Procedure

- Step 1 Log in to the webpage of VTS.
- Step 2 Select **Security > CA Certificate > Device Certificate**.
- Step 3 Click **Install Device Certificate**.
- Step 4 Select **Install Existing Certificate**, and then click **Next**.
- Step 5 Click **Browse** to select the certificate and private key file.
Enter the private key password if the private key file is encrypted.

Figure 3-48 Certificate and private key

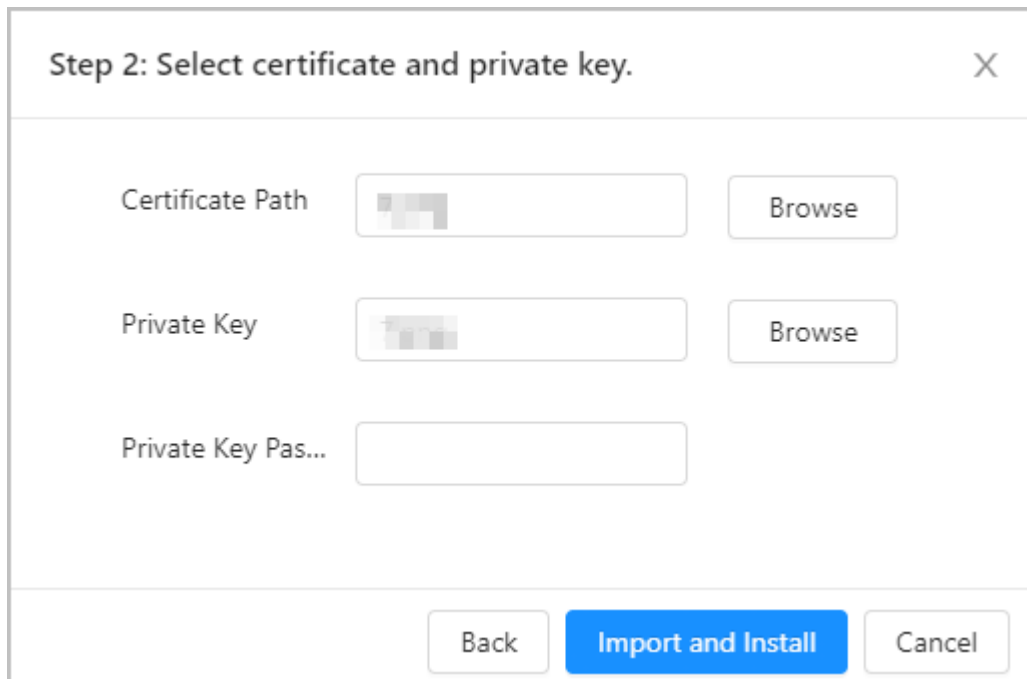

Step 2: Select certificate and private key. X

Certificate Path Browse

Private Key Browse

Private Key Pas...

Back Import and Install Cancel

Related Operations

- Click **Enter Edit Mode** to edit the custom name of the certificate.
- Click  to download the certificate.

- Click  to delete the certificate.

3.2.8.5 Installing Trusted CA Certificate



CA certificate is a digital certificate for the legal identity of the camera. For example, when the camera accesses the LAN through 802.1x, the CA certificate is required.

Procedure

- Step 1 Log in to the webpage of VTS.
- Step 2 Select **Security** > **CA Certificate** > **Trusted CA Certificate**.
- Step 3 Click **Install Trusted Certificate**.

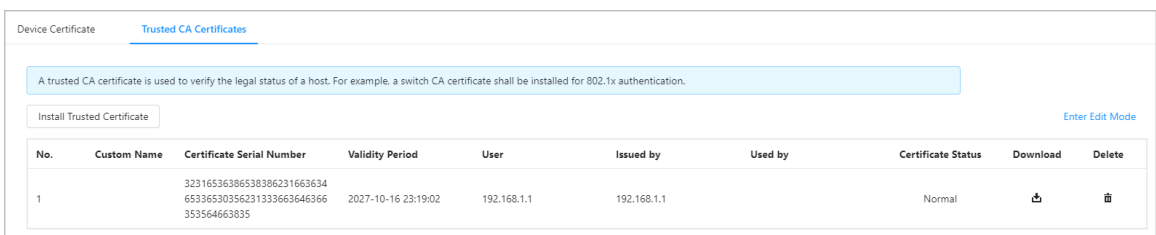
Figure 3-49 Install trusted certificate





No.	Custom Name	Certificate Serial Number	Validity Period	User	Issued by	Used by	Certificate Status	Download	Delete
1		32316536386538386231663634 65326530356231333663646366 353564663835	2027-10-16 23:19:02	192.168.1.1	192.168.1.1		Normal		

- Step 4 Click **Browse** in the pop-up window to select the certificate.
- Step 5 Click **OK** to import the trusted certificate.

After the certificate is imported successfully, you can view the imported certificate on the **Trusted CA Certificate** page.

Related Operations

- Click **Enter Edit Mode** to edit the custom name of the certificate.
- Click  to download the certificate.
- Click  to delete the certificate.

3.2.8.6 Configuring Video Encryption

The device supports audio and video encryption during data transmission.

Background Information



We recommend you enable video encryption function. There might be safety risk if this function is disabled.

Procedure

- Step 1 Log in to the webpage of VTS.
- Step 2 Select **Security** > **Video Encryption**.
- Step 3 Configure the parameters.

Figure 3-50 Video encryption

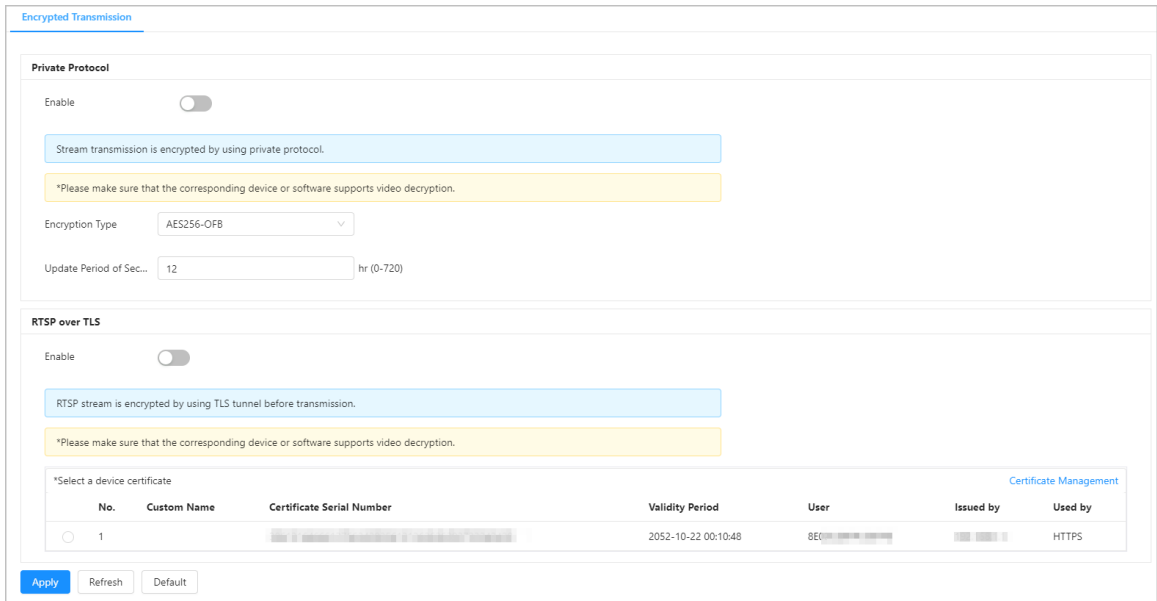

Table 3-20 Description of video encryption parameters

Area	Parameter	Description
Private Protocol	Enable	Enable stream frame encryption by using private protocol.
	Encryption Type	Click <input type="checkbox"/> to enable audio and video encryption during data transmission. Select the encryption type, and then configure update period of secret key.
	Update Period of Secret Key	<ul style="list-style-type: none"> ● Encryption Type : Use the default setting. ● Update Period of Secret Key : Value range is 0–720 hours. 0 means never update the secret key.
RTSP over TLS	Enable	Enables RTSP stream encryption by using TLS. Click <input type="checkbox"/> , and then select a device certificate from certificate list.
	Certificate Management	For details about certificate management, see "3.2.8.4 Installing Device Certificate". Created certificate of imported certificate are displayed in Select a device certificate list.

4 Industrial Scenes

4.1 Operations on Local Device

This chapter introduces different configurations in industrial scene. Other configurations are the same with that in buildings scene.

4.1.1 Local Screen

Figure 4-1 Local screen

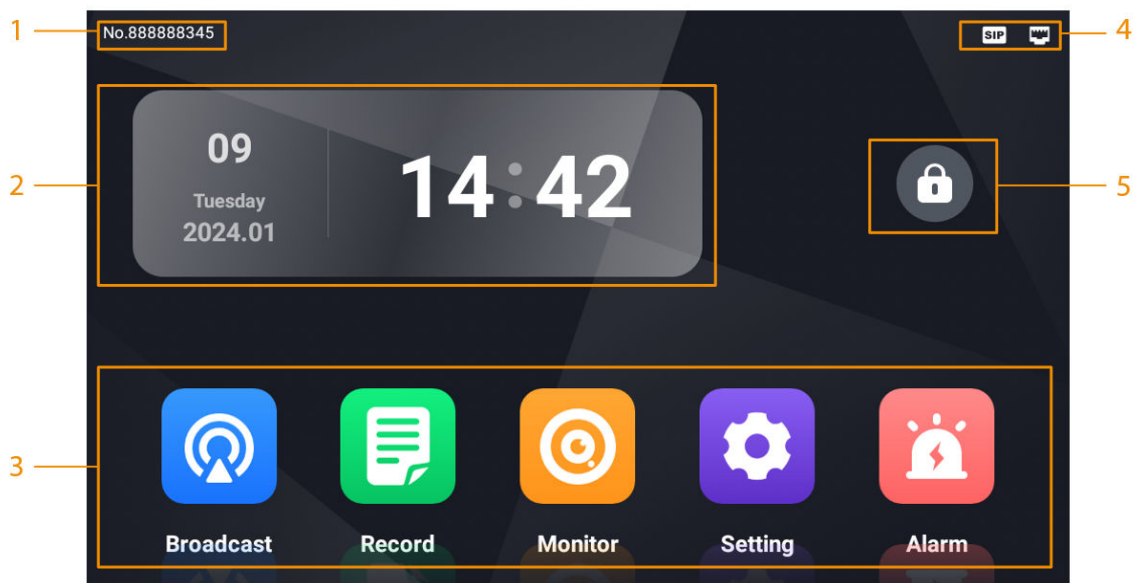





Table 4-1 Home screen introduction

No.	Description
1	The number of VTS.
2	Date and time.
3	Function buttons. <ul style="list-style-type: none">• Broadcast: Play the voice or manual broadcasting on part of terminal devices or all terminal devices. For details, see "4.1.5.1 Broadcasting".• Record: Check the call history, video files and snapshot files. For details, see "4.1.5.2 Record".• Monitor: Monitor VTA and IPC. For details, see "4.1.5.3 Monitoring".• Setting: Enter the setting screen of VTS. For details, see "4.1.4 Project Settings".• Alarm: Displays the alarm messages reported by the VTA.

No.	Description
4	<p>Tap  to lock the screen.</p> <p></p> <p>If you select Setting > Display Settings, and turn on Lock Screen, you need to enter the default password 123456 to unlock the screen when you lock it after the configuration.</p>
5	The connection status of the network, the SIP server, and the SD card.

4.1.2 Configuring Intercom Parameters

On the home screen, select **Setting** > .

- The SIP server is not enabled: The parameters are the same with the parameters of building scene. For details, see "3.1.4 Configuring the Intercom Parameters".
- The SIP server is enabled: You can enable or disable **Always Forward**. After enabled, the call will be forwarded to other devices that you configured on the platform.

Figure 4-2 Intercom settings

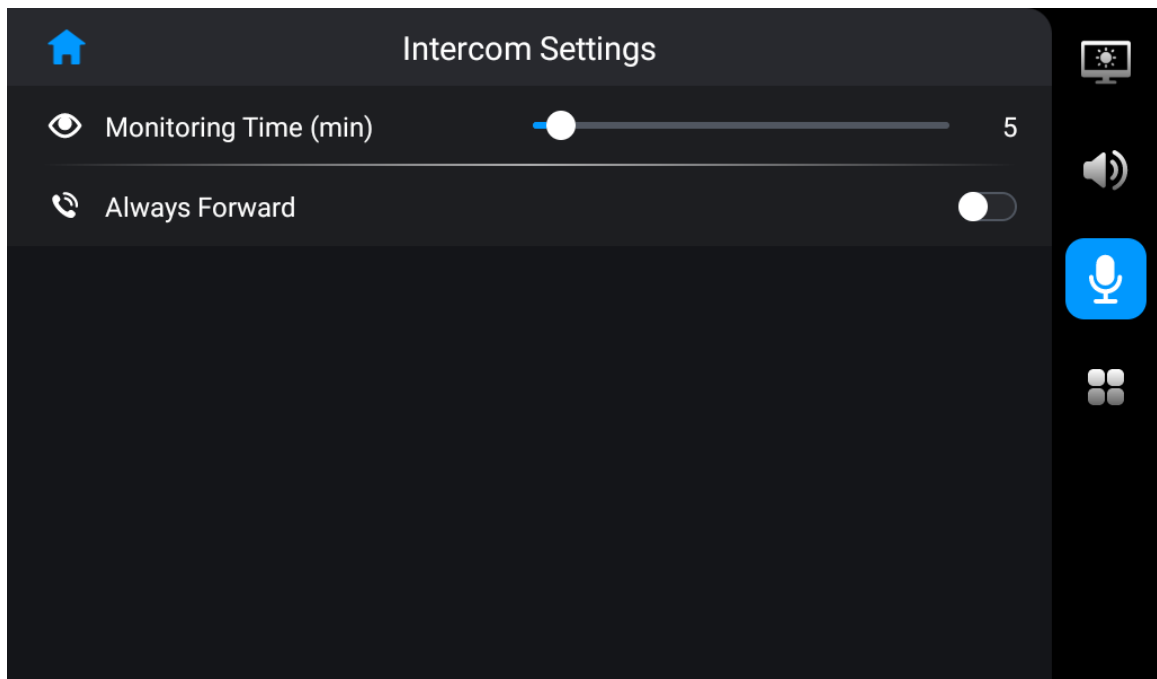

4.1.3 Configuring the Advanced Parameters

The configurations of the advanced settings are the same with that in buildings scene. For details, see "3.1.5 Configuring the Advanced Parameters".



Receive Alarm Info from VTHs is not available under industrial scene.

4.1.4 Project Settings

4.1.4.1 Configuring VTS

Configure the number and network parameters of VTS.

Procedure



- Step 1** Select **Settings** >  > **Project Setting** on the home screen.
- Step 2** Enter the password, and then tap **OK**.
- Step 3** Tap , and then configure the parameters.

Figure 4-3 Configure the parameters

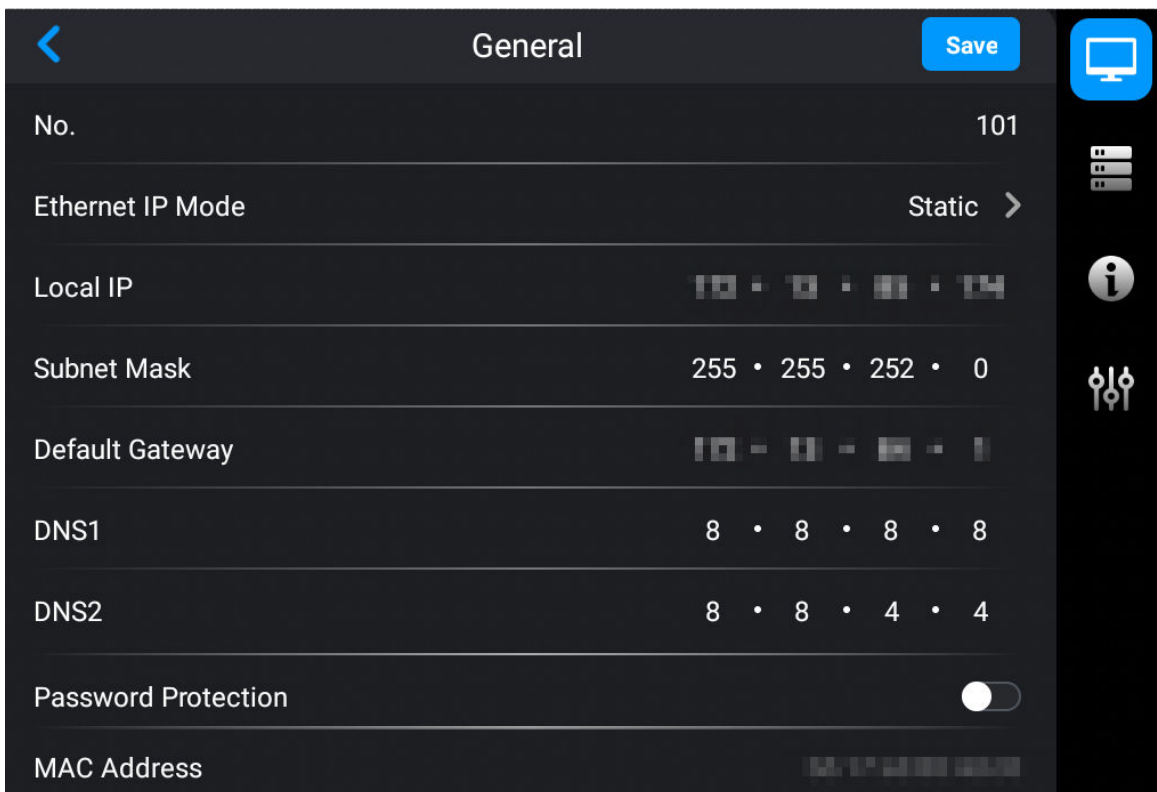

Table 4-2 Description of VTS parameters

Parameter	Description
No.	User-defined. You can configure the number from 101 to 999.
Ethernet IP Mode	Configure the mode to get the IP. <ul style="list-style-type: none"> Static: Manually set Local IP, Subnet Mask and Default Gateway. DHCP (Dynamic Host Configuration Protocol): Select DHCP if there is a DHCP server. The device automatically gets a dynamic IP address.
Local IP	If you select Static in Ethernet IP Mode , configure the IP address, subnet mask and default gateway according to the network planning.
Subnet Mask	

Parameter	Description
Default Gateway	
DNS 1	IP address of DNS server.
DNS 2	Standby IP address of DNS server.
Password Protection	Turn on password protection. The password is transferred in encryption when the device is registered on the platform through SIP.

4.1.4.2 Configuring Protocols

Procedure



- Step 1** Select **Settings** >  > **Project Setting** on the home screen.
- Step 2** Enter the password, and then tap **OK**.
- Step 3** Tap , and then configure the parameters.
- If VTS does not need the platform to connect, select **Private Protocol**.
 - If VTS is connected to the platform through SIP agreement, select **SIP Server**, and then configure the parameters.

Table 4-3 Description of SIP server parameters

Parameter	Description
IP Address	IP address of SIP server.
Network Port	Network port number of SIP server. The platform as the SIP server: 5080.
Username	Default.
Password	Default.
Domain Name	Keep consistent with the SIP server. VDP as default.

- Step 4** Tap **Save**.

4.1.5 Commissioning

4.1.5.1 Broadcasting

Play the voice or manual broadcasting on part of terminal devices or all terminal devices.

4.1.5.1.1 Broadcasting on Part of the Devices

Procedure

- Step 1** Tap **Broadcast** on the home screen of VTS.
- Step 2** Select the terminal devices, and then tap **OK**.

Figure 4-4 Select the terminal devices

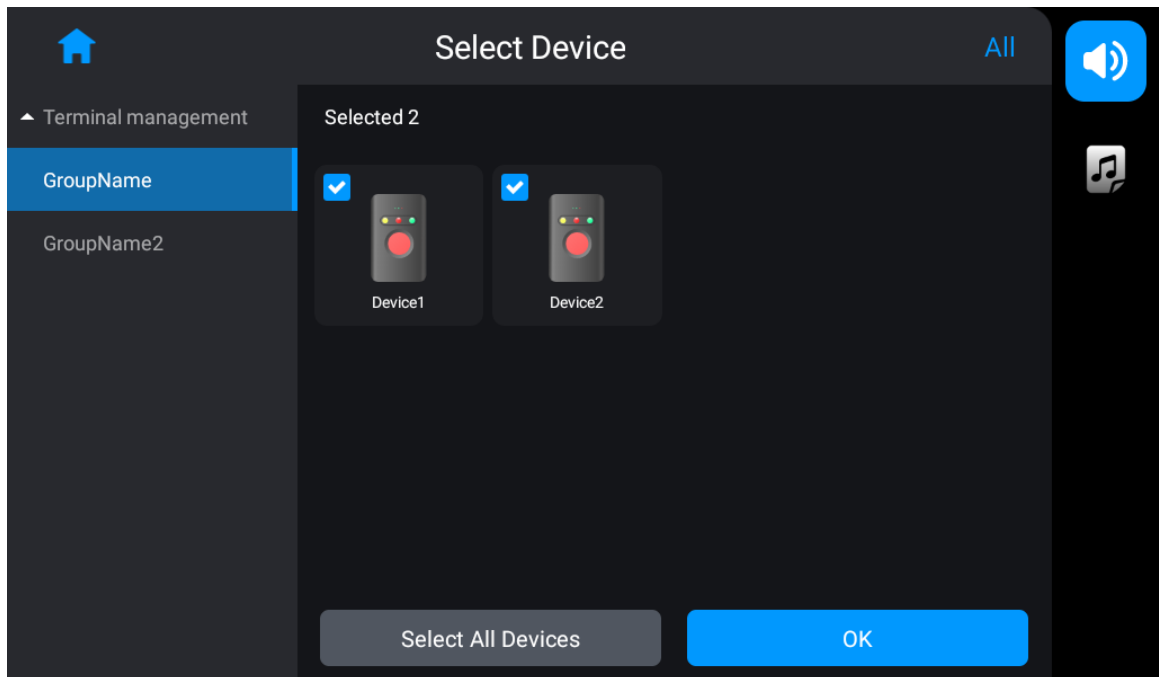

Step 3 Select **Broadcast Type**, and then tap **Start Broadcast**.

- Audio File: Select the audio in the audio file list, and then tap **Start Broadcast** to play the audio.
- Manual Broadcast: Tap **Start Broadcast**, and then tap  to broadcast.

Figure 4-5 Audio broadcasting

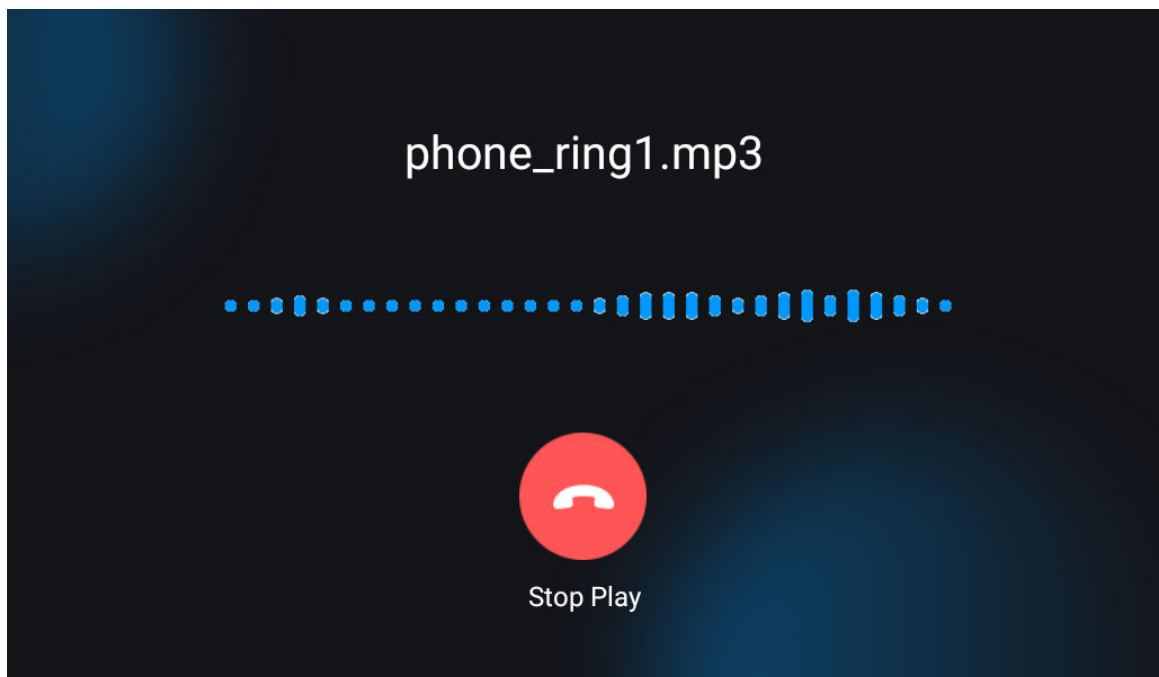
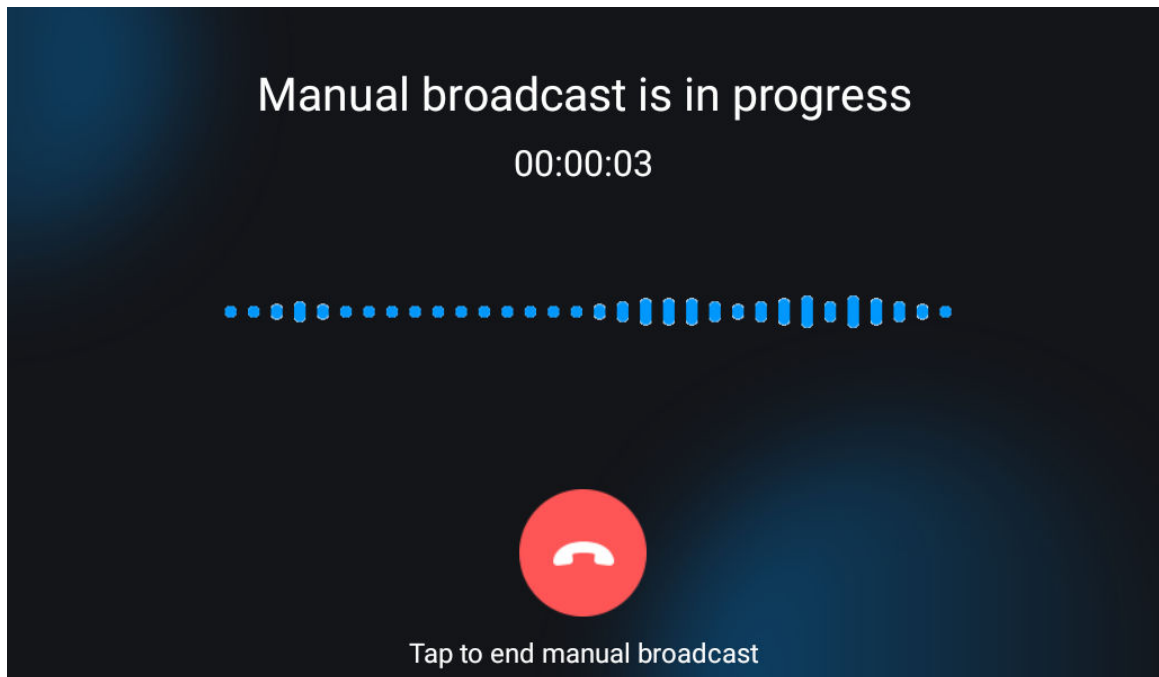



Figure 4-6 Manual broadcasting



4.1.5.1.2 Broadcasting on All Devices

Procedure

- Step 1 Tap **Broadcast** on the home screen of VTS.
- Step 2 Tap **Select All Devices**.
- Step 3 Select **Broadcast Type**, and then start broadcast.
 - Audio File: Select the audio in the audio file list, and then tap **Start Broadcast** to play the audio.
 - Manual Broadcast: Tap **Start Broadcast**, and then tap  to broadcast.

4.1.5.2 Record

Check the call history, the missed call records, video files and snapshot files.

Call History



- Tap the call on call history list to call back.
- : Check the snapshot files of the call.
- : Check the video files of the call.

Figure 4-7 Call history



Video

Figure 4-8 Video files

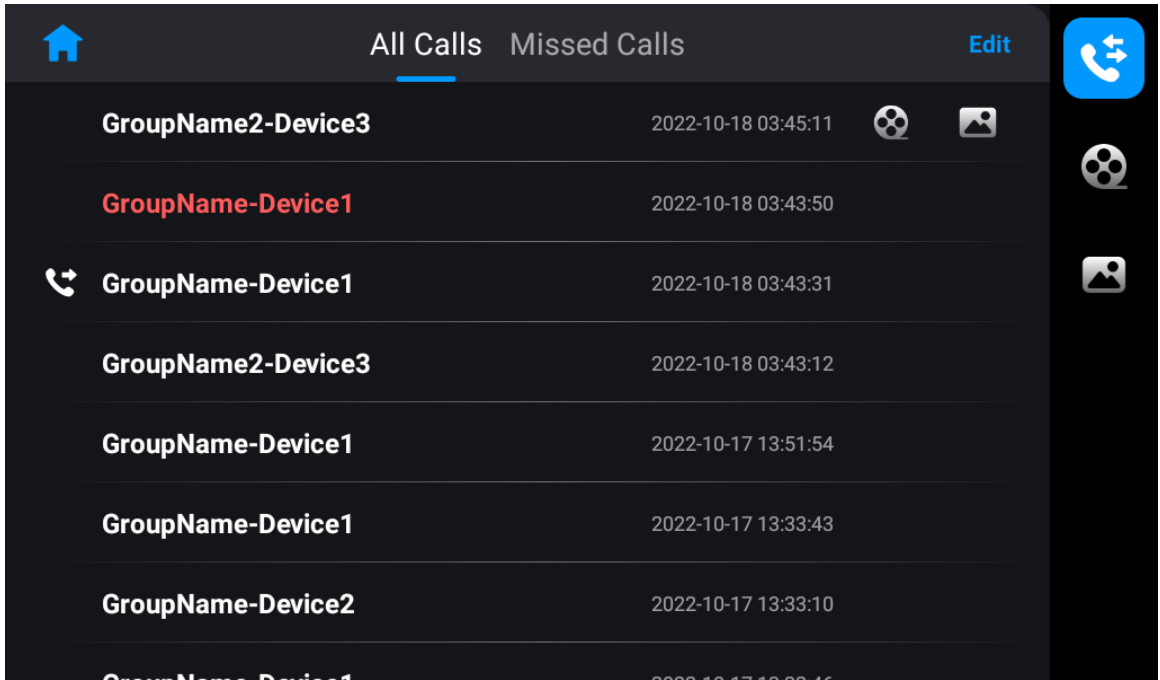
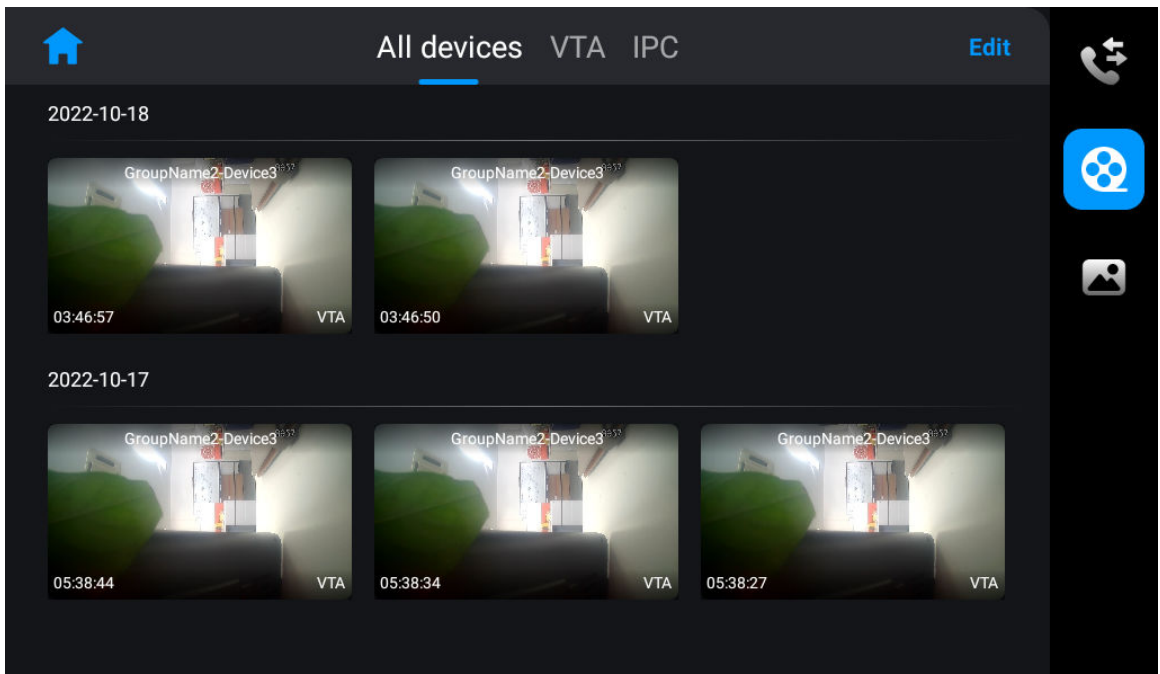

Snapshot

Figure 4-9 Snapshot files

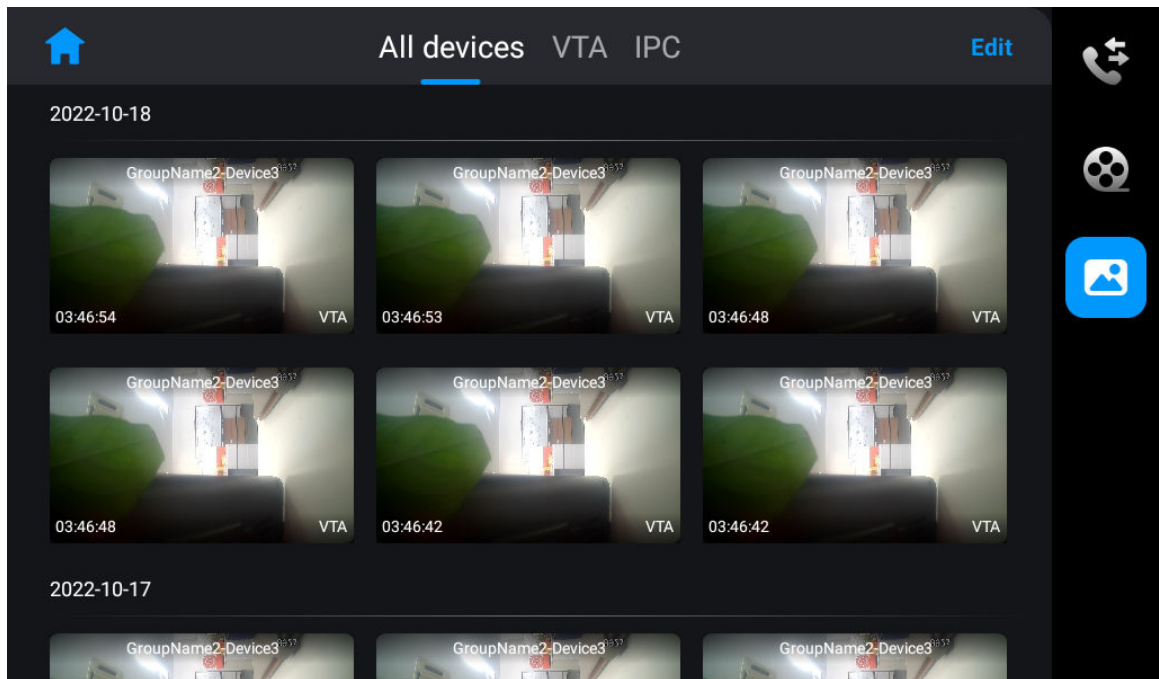

4.1.5.3 Monitoring

- VTS as the lower-level VTS: You can monitor and call VTA. IPC and VTA receive the call.
- VTS as the upper-level VTS: You can monitor and call VTA.

Use monitoring VTA as an example.

Tap **Monitor** on the home screen of VTS, and then tap the icon of VTA.

Figure 4-10 Monitor VTA

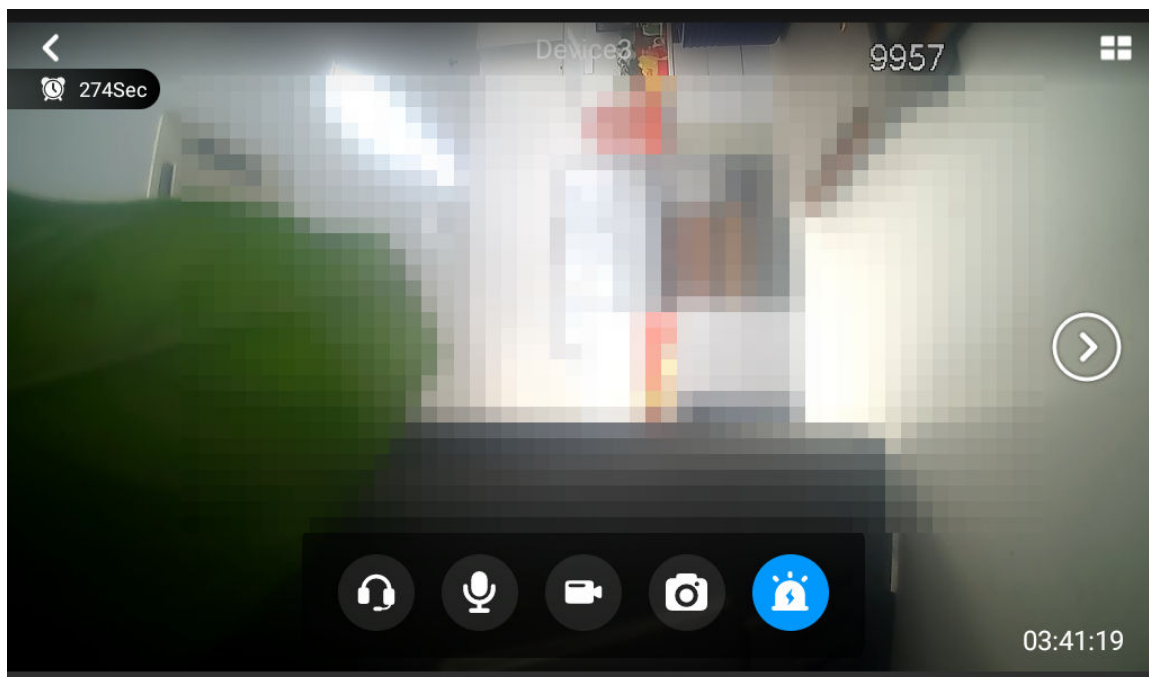











Table 4-4 Monitoring image description

Icon	Description
	Tap to view the monitoring image in 4 windows.
	Tap to convert to monitoring image of other terminal devices if VTS connects more than one terminal devices.
	Tap to receive the audio from VTA.
	Talk with the peer device.
	Tap to start manual recording.
	Tap to manually snapshot.
	Control the alarm indicator of VTA. <ul style="list-style-type: none"> : The alarm indicator is on. : The alarm indicator is off.

4.2 Operations on Webpage

This section introduces different configurations of VTS in industrial scene. Other configurations are the same with that in buildings scene.

4.2.1 Configuring Device Role

Procedure

- Step 1 Log in to the webpage of the device.
- Step 2 Select **System** > **General**.
- Step 3 Configure the parameters.

Figure 4-11 Configure the parameters

The screenshot shows a configuration form with three input fields and three buttons. The 'Device Role' field is a dropdown menu currently set to 'Lower-level VTS'. The 'Device Name' field contains the text 'VTS'. The 'Device No.' field contains the number '101'. Below the fields are three buttons: 'Apply' (highlighted in blue), 'Refresh', and 'Default'.

Table 4-5 Description of the device role parameters

Parameter	Description
Device role	<p>Select from lower-level VTS, upper-level VTS and platform client. The information saved on the device will be cleared after you change the device role.</p> <ul style="list-style-type: none"> ● Lower-level VTS: Used as the lower-level VTS if there is no platform. It has the management permission of the device. You can add VTA and IPC. The operations of adding IPC are the same with that in buildings scene. ● Upper-level VTS: Used as the upper-level VTS if there is no platform. It has permissions to add lower-level VTS. It does not have permission to manage organizational structure. You can add lower-level VTS. ● Platform client: Used as the platform client if there is the platform. It does not have the management permission of the device.
Device name	You can configure the name that distinguishes the device.
Device No.	You can configure the number from 101 to 999.

- Step 4 Click **Apply**.

4.2.2 Configuring SIP Server

Configure the parameters of SIP server. Connect to VTA through SIP agreement to achieve video intercom.

Procedure

- Step 1 Log in to the webpage of VTS.
- Step 2 Select **Network Settings** > **SIP Server**.
- Step 3 Configure the parameters.

Figure 4-12 SIP server parameters

Table 4-6 Parameters description

Parameter	Description
IP Address	IP address of SIP server.
Port	Network port number of SIP server. The platform as the SIP server: 5080.
Username	Default.
Password	Default.
SIP Domain	Keep consistent with the SIP server. Domain name is VDP by default.

Step 4 Tap **Save**.

4.2.3 Configuring FTP

Get the audio file from FTP and play it.



If the SIP server is enabled, this function will not be displayed.

Procedure

- Step 1 Log in to the webpage.
- Step 2 Select **Network Settings** > **FTP**.
- Step 3 Turn on **Enable**, and then configure the IP address, port, user name and password.
- Step 4 Click **Apply**.

4.2.4 Device Setting

4.2.4.1 Using with the Platform

When using the device with the platform, enable the SIP server, and then configure the parameters.

4.2.4.1.1 Call Forwarding

Log in to the webpage of VTS, and then select **Device Setting** > **Call Forwarding**. Enable **Always Forward**, and then click **Apply**. Configure the device that receives the forwarding call, and the call will be forwarded.

Figure 4-13 Call forwarding

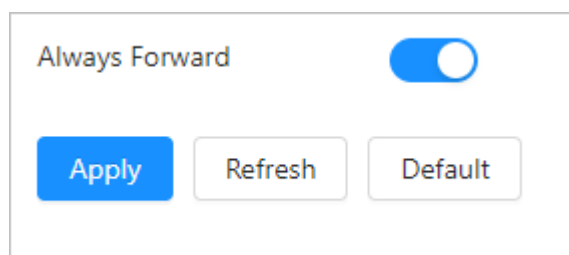

4.2.4.1.2 Device Management

Procedure

- Step 1 Log in to the webpage.
- Step 2 Select **Device Setting** > **Device Setting**.
- The devices that are sent by the platform are displayed.
- Step 3 (Optional) Add the organization.
1. Click +.
 2. Select main organization, and then enter the name.
 3. Click **OK**.

Figure 4-14 Add the organization

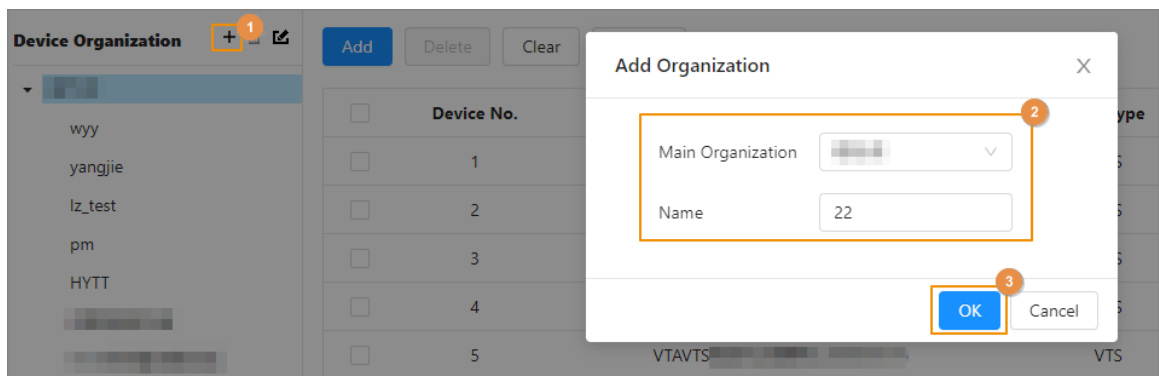

- Step 4 (Optional) Add the device.
- You can add VTS and VTA.
- VTS: Used as contacts.
 - VTA: You can call and monitor VTA on the VTS.

1. Click **Add**.
2. Configure the parameters, and then click **OK**.

4.2.4.2 Using without the Platform

When using the device without the platform, configure the device role as lower-level VTS or upper-level VTS.

4.2.4.2.1 Call Forwarding

Manage the forwarding and receiving of the call between the VTS devices.

When the call of device A is forwarded to device B, configure **Forwarding** on device A, and then configure **Receiving** on device B. If you only configure one side, that call fails to be forwarded.

Forwarding

Configure the forwarding, and the call of the current VTS will be entrusted or forwarded to the VTS that you configured.

1. Log in to the webpage.
2. Select **Device Setting** > **Call Forwarding** > **Forwarding**.
3. Click **Add**.
4. Configure the parameters.

Figure 4-15 Add the VTS for forwarding the call

Table 4-7 Description of forwarding parameters

Parameter	Description
IP Address	The IP address of the VTS that receives the forwarding call.

Parameter	Description
Service	<ul style="list-style-type: none"> ● Regular call: Intercom between VTS and other VTS. ● Entrusting: All calls of the current VTS will be forwarded to other VTS. ● Call Forwarding: If the current VTS missed the call, the call will be forwarded to other VTS.
Username	The username and the password of the VTS that receives the forwarding call.
Password	

5. Click **OK**.

Receiving

Configure the receiving, and the current VTS will receive the call that peer VTS entrusted or forwarded.

1. Log in to the webpage.
2. Select **Device Setting** > **Call Forwarding** > **Receiving**.
3. Click **Add**.
4. Enter the IP address, username and password of other VTS.
5. Click **OK**.

4.2.4.2.2 Adding VTA

When the device is configured as lower-level VTS, you can add VTA and IPC. The operations of adding IPC are the same with the operations in building scene. This section introduces the operations of adding VTA.

Procedure

- Step 1 Log in to the webpage of VTS.
- Step 2 Select **Device Setting** > **Terminal Management**.
- Step 3 Click **Add**, and then configure the parameters.

Figure 4-16 Add VTA

The screenshot shows a dialog box titled "Add" with a close button (X) in the top right corner. The dialog contains the following fields and values:

- Device No.: 1010002
- Device Type: VTA (dropdown menu)
- Group: test
- Device Name: Alarm
- Device Model: VTA
- Upper Level: VTS
- Add Mode: IP Address (dropdown menu)
- IP Address: [Dotted mask]
- Username: admin
- Password: [Dotted mask]

At the bottom right of the dialog, there are two buttons: "OK" (blue) and "Cancel" (white).

Table 4-8 Parameters description

Parameter	Description
Group	Select Monitor > Terminal Management on the VTS, and then you can view the devices of the group that you configured.
Device Name	User-defined.
Device Model	Enter the complete device model that you can get from the device label.
Add Mode	You can add VTA in the following 2 ways. <ul style="list-style-type: none"> ● IP address: Enter the IP address of the VTA. ● Register: Configure the parameters for registering on the VTS.
Username	Enter the username and password of the device that you added.
Password	

Step 4 Click **OK**.

4.2.4.2.3 Adding Lower-level VTS

When the device is configured as upper-level VTS, you can add the lower-level VTS.

Procedure

- Step 1 Log in to the webpage of the device.
- Step 2 Select **Device Setting** > **Terminal Management**.
- Step 3 Click **Add**.
- Step 4 Enter IP address, username and password of the VTS.

Figure 4-17 Add lower-level VTS

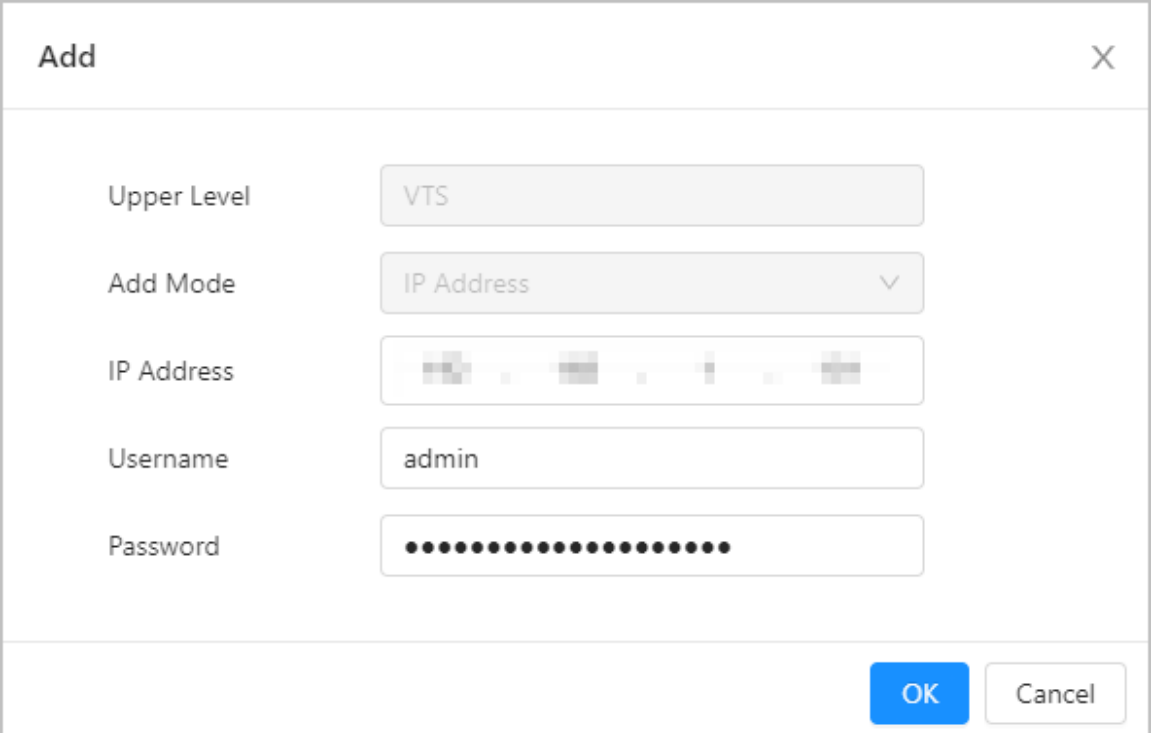

The screenshot shows a dialog box titled "Add" with a close button "X" in the top right corner. The dialog contains the following fields:

- Upper Level:** A dropdown menu with "VTS" selected.
- Add Mode:** A dropdown menu with "IP Address" selected.
- IP Address:** A dotted input field for entering an IP address.
- Username:** A text input field containing "admin".
- Password:** A masked input field with 15 dots.

At the bottom right of the dialog, there are two buttons: "OK" (blue) and "Cancel" (white).

- Step 5 Click **OK**.

Appendix 1 Cybersecurity Recommendations

Mandatory actions to be taken for basic device network security:

1. Use Strong Passwords

Please refer to the following suggestions to set passwords:

- The length should not be less than 8 characters.
- Include at least two types of characters; character types include upper and lower case letters, numbers and symbols.
- Do not contain the account name or the account name in reverse order.
- Do not use continuous characters, such as 123, abc, etc.
- Do not use overlapped characters, such as 111, aaa, etc.

2. Update Firmware and Client Software in Time

- According to the standard procedure in Tech-industry, we recommend to keep your device (such as NVR, DVR, IP camera, etc.) firmware up-to-date to ensure the system is equipped with the latest security patches and fixes. When the device is connected to the public network, it is recommended to enable the "auto-check for updates" function to obtain timely information of firmware updates released by the manufacturer.
- We suggest that you download and use the latest version of client software.

"Nice to have" recommendations to improve your device network security:

1. Physical Protection

We suggest that you perform physical protection to device, especially storage devices. For example, place the device in a special computer room and cabinet, and implement well-done access control permission and key management to prevent unauthorized personnel from carrying out physical contacts such as damaging hardware, unauthorized connection of removable device (such as USB flash disk, serial port), etc.

2. Change Passwords Regularly

We suggest that you change passwords regularly to reduce the risk of being guessed or cracked.

3. Set and Update Passwords Reset Information Timely

The device supports password reset function. Please set up related information for password reset in time, including the end user's mailbox and password protection questions. If the information changes, please modify it in time. When setting password protection questions, it is suggested not to use those that can be easily guessed.

4. Enable Account Lock

The account lock feature is enabled by default, and we recommend you to keep it on to guarantee the account security. If an attacker attempts to log in with the wrong password several times, the corresponding account and the source IP address will be locked.

5. Change Default HTTP and Other Service Ports

We suggest you to change default HTTP and other service ports into any set of numbers between 1024–65535, reducing the risk of outsiders being able to guess which ports you are using.

6. Enable HTTPS

We suggest you to enable HTTPS, so that you visit Web service through a secure communication channel.

7. MAC Address Binding

We recommend you to bind the IP and MAC address of the gateway to the device, thus reducing the risk of ARP spoofing.

8. Assign Accounts and Privileges Reasonably

According to business and management requirements, reasonably add users and assign a minimum set of permissions to them.

9. **Disable Unnecessary Services and Choose Secure Modes**

If not needed, it is recommended to turn off some services such as SNMP, SMTP, UPnP, etc., to reduce risks.

If necessary, it is highly recommended that you use safe modes, including but not limited to the following services:

- SNMP: Choose SNMP v3, and set up strong encryption passwords and authentication passwords.
- SMTP: Choose TLS to access mailbox server.
- FTP: Choose SFTP, and set up strong passwords.
- AP hotspot: Choose WPA2-PSK encryption mode, and set up strong passwords.

10. **Audio and Video Encrypted Transmission**

If your audio and video data contents are very important or sensitive, we recommend that you use encrypted transmission function, to reduce the risk of audio and video data being stolen during transmission.

Reminder: encrypted transmission will cause some loss in transmission efficiency.

11. **Secure Auditing**

- Check online users: we suggest that you check online users regularly to see if the device is logged in without authorization.
- Check device log: By viewing the logs, you can know the IP addresses that were used to log in to your devices and their key operations.

12. **Network Log**

Due to the limited storage capacity of the device, the stored log is limited. If you need to save the log for a long time, it is recommended that you enable the network log function to ensure that the critical logs are synchronized to the network log server for tracing.

13. **Construct a Safe Network Environment**

In order to better ensure the safety of device and reduce potential cyber risks, we recommend:

- Disable the port mapping function of the router to avoid direct access to the intranet devices from external network.
- The network should be partitioned and isolated according to the actual network needs. If there are no communication requirements between two sub networks, it is suggested to use VLAN, network GAP and other technologies to partition the network, so as to achieve the network isolation effect.
- Establish the 802.1x access authentication system to reduce the risk of unauthorized access to private networks.
- Enable IP/MAC address filtering function to limit the range of hosts allowed to access the device.