

8-Port 10/100/1000Mbps 802.3at PoE Desktop Switch

GSD-808HP

User's Manual

Trademarks

Copyright © PLANET Technology Corp. 2011.

Contents subject to revision without prior notice.

PLANET is a registered trademark of PLANET Technology Corp. All other trademarks belong to their respective owners.

Disclaimer

PLANET Technology does not warrant that the hardware will work properly in all environments and applications, and makes no warranty and representation, either implied or expressed, with respect to the quality, performance, merchantability, or fitness for a particular purpose.

PLANET has made every effort to ensure that this User's Manual is accurate; PLANET disclaims liability for any inaccuracies or omissions that may have occurred.

Information in this User's Manual is subject to change without notice and does not represent a commitment on the part of PLANET. PLANET assumes no responsibility for any inaccuracies that may be contained in this User's Manual. PLANET makes no commitment to update or keep current the information in this User's Manual, and reserves the right to make improvements to this User's Manual and/or to the products described in this User's Manual, at any time without notice.

If you find information in this manual that is incorrect, misleading, or incomplete, we would appreciate your comments and suggestions.

FCC Warning

This equipment has been tested and found to comply with the limits for a Class A digital device, pursuant to Part 15 of the FCC Rules. These limits are designed to provide reasonable protection against harmful interference when the equipment is operated in a commercial environment. This equipment generates, uses, and can radiate radio frequency energy and, if not installed and used in accordance with the Instruction manual, may cause harmful interference to radio communications. Operation of this equipment in a residential area is likely to cause harmful interference in which case the user will be required to correct the interference at his own expense.

CE Mark Warning

This is a Class A product. In a domestic environment, this product may cause radio interference, in which case the user may be required to take adequate measures.

Energy Saving Note of the Device

This power required device does not support Standby mode operation.

For energy saving, please remove the power cable to disconnect the device from the power circuit.

Without removing power cable, the device will still consuming power from the power source. In the view of Saving the Energy and reduce the unnecessary power consuming, it is strongly suggested to remove the power connection for the device if this device is not intended to be active.

WEEE Warning



To avoid the potential effects on the environment and human health as a result of the presence of hazardous substances in electrical and electronic equipment, end users of electrical and electronic equipment should understand the meaning of the crossed-out wheeled bin symbol. Do not dispose of WEEE as unsorted municipal waste and have to collect such WEEE separately.

Revision

PLANET 8-Port 10/100/1000Mbps 802.3at PoE Desktop Switch User's Manual

For Model: GSD-808HP

Revision: 1.0 (September, 2011)

Part No.: 2350-A35130-000

Table of Contents

1. Introduction.....	5
1.1 Checklist.....	5
1.2 Product Description.....	5
1.3 Features	6
1.4 Specification.....	7
2. Hardware Description	9
2.1 Front Panel	9
2.1.1 LED Indicators.....	9
2.2 Rear Panel	10
2.3 Desktop Installation	11
2.4 Rack Mounting	12
2.5 Product Application	14
2.5.1 Train Station	14
2.5.2 IP Office	15
2.6 Power over Ethernet Powered Device	16
3. Power over Ethernet Overview.....	17
4. Troubleshooting.....	20
Appendix A Networking Connection	21
A.1 PoE Switch RJ-45 Port Pin Assignments (Port 1 to Port-8).....	21
A.2 Switch's RJ-45 Pin Assignments - 1000Mbps, 1000Base-T	21
A.3 10/100Mbps, 10/100Base-TX.....	22

1. Introduction

1.1 Checklist

Check the contents of your package for following parts:

- GSD-808HP x 1
- User's Manual x 1
- 19" Rack Mount Accessory Kit x 1
- Rubber Feet x 4
- Power Cord x 1

If any of these pieces are missing or damaged, please contact your dealer immediately, if possible, retain the carton including the original packing material, and use them against to repack the product in case there is a need to return it to us for repair.

1.2 Product Description

To fulfill the demand of High Power PoE for network applications with Gigabit speed transmission, the new member in PLANET 808.3at PoE Gigabit Ethernet Switch family -GSD-808HP is an ideal solution. Each 10/100/1000Mbps port of GSD-808HP features **IEEE 802.3af** and **High Power IEEE 802.3at** Power over Ethernet (PoE) that combines up to **130 Watts** power output and data per port over one Cat.5e / 6 Ethernet cable, with totally **130 Watts** PoE budget on whole system, it is designed specifically to satisfy the growing demand of higher power consuming network PD (powered devices) such as **PTZ** (Pan, Tilt & Zoom) / **Speed Dome network cameras**, multi- channel (802.11a / b / g / n) wireless LAN access points and other network devices by providing double PoE power than conventional 802.3af PoE currently.

The 8 Gigabit High Power PoE ports in the GSD-808HP support both 802.3af and 802.3at PoE standards and allows users flexibly connect standard and high powered devices simultaneously. By offering **130 Watts** PoE budget, eight 15.4 Watts IEEE 802.3af devices or four 30 Watts IEEE 802.3at devices can be easily installed without the power-socket limitation.

To facilitate power management, the GSD-808HP is implemented powerful PoE management feature, the **over temperature protection** to prevent power budget overloading. The four orange LEDs hardware designed that located on right side of GSD-808HP front panel, it call "**PoE Power Usage**" and its meaning of lower to upper LED is **25%, 50%, 75% and 95%**. With these LED indications, you can monitor current PoE power used status of GSD-808HP easily and efficiently.

■

Providing data transfer and High Power PoE in one unit, the GSD-808HP shall reduce the need of extension cables and dedicated electrical outlets on the wall, ceiling or any unreachable place. It helps to lower the installation costs and simplify the installation effort. Besides, the first important key feature is energy saving. With more efficient switching power supply, the efficiency of the GSD-808HP would be much better than eight linear power adapters in the long run. Furthermore, it is the ideal device for bridging among Fast Ethernet and Gigabit Ethernet workgroups and networks. With Gigabit throughput and eight IEEE 802.3af / 802.3at PoE interfaces supported, the GSD-808HP is ideal for small business and workgroups to efficiently deploy the High Power PoE network for the wireless access points, IP-based surveillance camera or IP phones in any places.

The GSD-808HP features high performance switch architecture capable of providing the non-blocking 16Gbps switch fabric and wire-speed throughput as high as 11.9Mpps, which greatly simplifies the tasks of upgrading the LAN for catering to increasing bandwidth demands. Besides, the 802.3x Full-Duplex flow control function of the GSD-808HP enables PD devices and servers directly connect to the Switch for wire-speed packet transfer performance without risk of packet loss.

All RJ-45 copper interfaces in the GSD-808HP support 10/100/1000Mbps Auto-Negotiation for optimal speed detection through RJ-45 Category 6, 5 or 5e cables. It also supports standard Auto-MDI/MDI-X that can detect the type of connection to any Ethernet device without requiring special straight or crossover cables.

1.3 Features

■ RJ-45 Interface

- 8-Port 10/100/1000Mbps Gigabit Ethernet ports
- 8-Port supports 56V DC power to PoE Powered Device

■ PoE

- Complies with IEEE 802.3af / 802.3at Power over Ethernet End-Span PSE
- Up to 8 IEEE 802.3af / 802.3at devices powered
- Supports PoE Power up to 30 Watts for each 802.3at PoE port
- Over Temperature Protection support
- Auto detect powered device (PD)
- Circuit protection prevents power interference between ports
- Remote power feeding up to 100m

■ Switching

- Hardware based 10/100/1000Mbps Auto-Negotiation and Auto MDI/MDI-X

- Flow control for Full Duplex operation and back pressure for Half Duplex operation
- Integrates address look-up engine, supporting 8K absolute MAC addresses
- 9K Jumbo Frame supports at all speed (10/100/1000Mbps)
- Automatic address learning and address aging
- Hardware
 - 13-inch desktop size, rack mountable; 1U height
 - LED indicators for system Power, Fan Failure, per port speed, Link / Act
 - LED indicators for per port PoE In-Use and PoE Power Usage (25%, 50%, 75% and 95%)
 - 1 silent FAN to provide stable and efficient power performance
 - Energy-Saving technology
 - Link down power saving
 - Intelligent scales power based on cable length

1.4 Specification

Model	GSD-808HP
Hardware Specification	
Network Connector	8-Port RJ-45 for 10/100/1000Base-T
PoE Inject Port	8-Port with 802.3af / 802.3at PoE injector function
LED Display	System: Power x 1 (Green), FAN Alert x 1 (Orange), PoE Power Usage x 4 (Orange) Per Port: PoE In-use (Orange), Speed (Green), LNK/ACT (Green)
Switch Architecture	Store and Forward switch architecture
MAC Address Table	8K MAC address table with Auto learning function
Switch Fabric	16Gbps
Switch Throughput	11.9Mpps
Jumbo Packet Size	9K Bytes
Flow Control	Back pressure for Half-Duplex. IEEE 802.3x Pause Frame for Full-Duplex
Power Requirement	AC 100~240V, 50/60Hz, 1.5A
Power Consumption	150 Watts / 511BTU

Dimension (W x D x H)	330 x 155 x 43.5mm	
Weight	1.56kg	
Power over Ethernet		
PoE Standard	IEEE 802.3af / 802.3at Power over Ethernet / PSE	
PoE Power Supply Type	End-Span	
PoE Power Output	Per Port 56V DC, 275mA. Max. 15.4 Watts (IEEE 802.3af) Per Port 56V DC, 535mA. Max. 30 Watts (IEEE 802.3at)	
Power Pin Assignment	1/2(+), 3/6(-)	
PoE Power Budget	130 Watts	
Max. number of Class 2 PD	8	
Max. number of Class 3 PD	8	
Max. number of Class 4 PD	4	
Standard Conformance		
EMI Safety	FCC Class A, CE	
Operating environment	0 ~ 50 Degree C	
Storage environment	-40 ~ 70 Degree C	
Operating Humidity	5 ~ 95%, Relative Humidity, non-condensing	
Storage Humidity	5 ~ 95%, Relative Humidity, non-condensing	
Standard Compliance	IEEE 802.3	Ethernet
	IEEE 802.3u	Fast Ethernet
	IEEE 802.3ab	Gigabit Ethernet
	IEEE 802.3x	Flow Control
	IEEE 802.3af	Power over Ethernet
	IEEE 802.3at	High Power over Ethernet

2. Hardware Description

This product provides three different running speeds – 10Mbps, 100Mbps and 1000Mbps in the same switch and automatically distinguishes the speed of incoming connection.

This section describes the hardware features of GSD-808HP. For easier management and control of the Switch, familiarize yourself with its display indicators, and ports. Front panel illustrations in this chapter display the unit LED indicators. Before connecting any network device to the GSD-808HP, please read this chapter carefully.

In the following section, the term **“Switch”** means the Switch device, ie. GSD-808HP; term of **“switch”** can be any third switches.

2.1 Front Panel

The Front Panel of the GSD-808HP PoE Ethernet Switch consists of 8x Auto-Sensing 10/100/1000Mbps Ethernet RJ-45 Ports. The LED Indicators are also located on the front panel of the GSD-808HP.

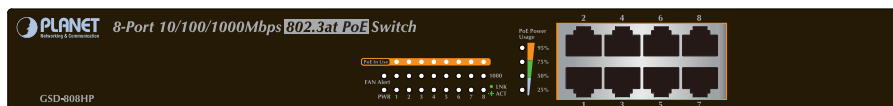

Figure 2-1: GSD-808HP Switch Front Panel

2.1.1 LED Indicators

System

LED	Color	Function
PWR	Green	Lights to indicate that the Switch has power.
FAN Alert	Orange	Lights to indicate that the FAN failure.

Per 10/100/1000Mbps Port

LED	Color	Function
PoE In-use	Orange	Lights to indicate the port is providing 56V DC in-line power. (1-8 ports)
Speed	Green	Lit: indicate the Switch is successfully connecting to the network at 1000Mbps. Off: indicate that the Switch is successfully connecting to the network at 10Mbps or 100Mbps.
LNK/ACT	Green	Lit: indicate the link through that port is successfully established. Blinks to indicate that the Switch is actively sending or receiving data over that port.

Per PoE Power Usage (Unit : %) (Lower LED to upper LED)

LED	Color	Function
25%	Orange	Lights to indicate the system has 25% PoE power usage.
50%	Orange	Lights to indicate the system has 50% PoE power usage.
75%	Orange	Lights to indicate the system has 75% PoE power usage.
95%	Orange	Lights to indicate the system has 95% PoE power usage.

2.2 Rear Panel

The rear panel of the GSD-808HP indicates an AC inlet power socket, which accepts input power from 100 to 240V AC, 50-60Hz. 1.5A and has a fan hole on the rear panel.



Figure 2-2: GSD-808HP Switch Rear Panel



Power
Notice

The device is a power-required device, it means, it will not work till it is powered. If your networks should active all the time, please consider using UPS (Uninterrupted Power Supply) for your device. It will prevent you from network data loss or network downtime. In some area, installing a surge suppression device may also help to protect your GSD-808HP from being damaged by unregulated surge or current to the GSD-808HP or the power adapter.

Before start up

Before your installation, please refer to the followings for your cabling:

10/100/1000Base-T

All 10/100/1000Base-T ports come with Auto-Negotiation capability. They automatically support 1000Base-T, 100Base-TX and 10Base-T networks. Users only need to plug a working network device into one of the 10/100/1000Base-T ports, and then turn on the GSD-808HP. The port will automatically runs in 10Mbps, 20Mbps, 100Mbps or 200Mbps and 1000Mbps or 2000Mbps after the negotiation with the connected device.

Cabling

Each 10/100/1000Base-T ports use RJ-45 sockets -- similar to phone jacks -- for connection of unshielded twisted-pair cable (UTP). The IEEE 802.3 / 802.3u 802.3ab Fast / Gigabit Ethernet standard requires Category 5 UTP for 100Mbps 100Base-TX. 10Base-T networks can use Cat.3, 4, 5 or 1000Base-T use 5/5e/6 UTP (see table below). Maximum distance is 100meters (328 feet).

Port Type	Cable Type	Connector
10Base-T	Cat 3, 4, 5, 2-pair	RJ-45
100Base-TX	Cat.5 UTP, 2-pair	RJ-45
1000Base-T	Cat.5/5e/6 UTP, 2-pair	RJ-45

Any Ethernet devices like hubs/ PCs can connect to the GSD-808HP by using straight-through wires. The eight-10/100/1000Mbps ports are auto-MDI/MDI-X can be used on straight-through or crossover cable.

2.3 Desktop Installation

To install the Switch on desktop, simply follow the next steps:

Step 1: Attach the rubber feet to the recessed areas on the bottom of the Switch, as shown in Figure 2-3.

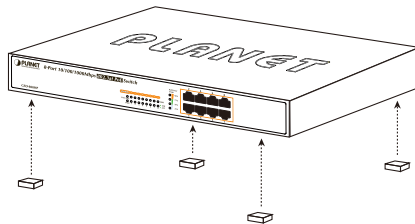

Figure 2-3: Place the Switch on the Desktop

Step 2: Place the Switch on desktop near an AC power source.

Step 3: Keep enough ventilation space between the Switch and the surrounding objects.



When choosing a location, please keep in mind the environmental restrictions discussed in Chapter 1, Section 4, in Specification.

Step 4: Connect your Switch to 802.3at / 802.3af complied Power Devices (PD) and other network devices.

- A.** Connect one end of a standard network cable to the 10/100/1000 RJ-45 ports on the Front of the Switch.
- B.** Connect the other end of the cable to the network devices such as printer servers, workstations or routers...etc.



Connection to the Switch requires UTP Category 5 network cabling with RJ-45 tips. For more information, please see the Cabling Specification in Appendix A.

Step 5 : Supply power to the Switch.

- A.** Connect one end of the power cable to the Switch.
- B.** Connect the power plug of the power cable to a standard wall outlet.

When the Switch receives power, the Power LED should remain solid Green.

2.4 Rack Mounting

To install the Switch in a 10-inch standard rack, follow the instructions described below.

Step 1: Place your Gigabit Ethernet Switch on a hard flat surface, with the front panel positioned towards your front side.

Step 2: Attach a rack-mount bracket to each side of the Switch with supplied screws attached to the package. Figure 2-4 shows how to attach brackets to one side of the Switch.

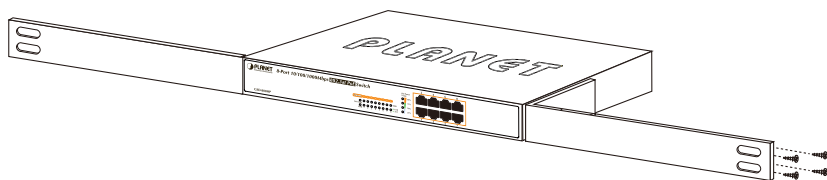

Figure 2-4: Attaching the Brackets to the Switch



You must use the screws supplied with the mounting brackets. Damage caused to the parts by using incorrect screws would invalidate the warranty.

Step 3: Secure the brackets tightly.

Step 4: Follow the same steps to attach the second bracket to the opposite side.

Step 5: After the brackets are attached to the Switch, use suitable screws to securely attach the brackets to the rack, as shown in Figure 2-5.

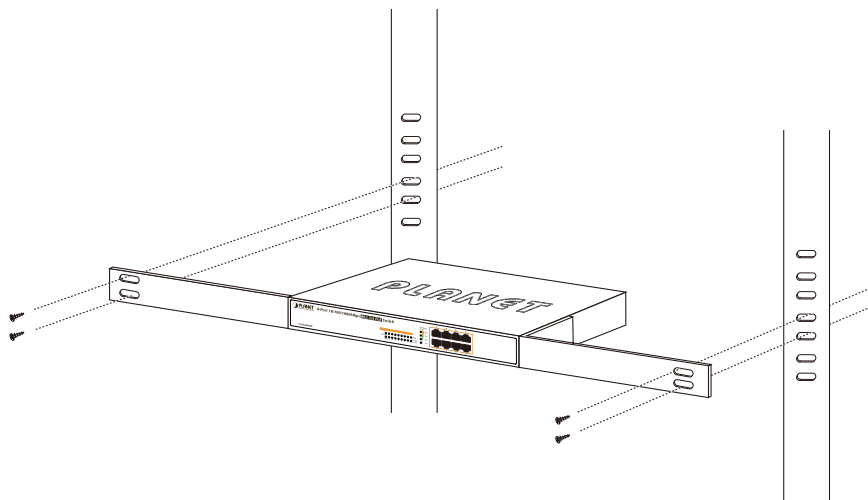

Figure 2-5: Mounting the Switch in a Rack

Step 6: Proceeds with the steps 4 and steps 5 of **session 2.3 Desktop Installation** to connect the network cabling and supply power to your Switch.

2.5 Product Application

2.5.1 Train Station

IEEE 802.3at Compliant IP Surveillance and Wireless Powered Devices

Having the capability of IEEE 802.3at Power over Ethernet standard, the GSD-808HP can directly connect with any IEEE 802.3at end-nodes like PTZ (Pan, Tilt & Zoom) network cameras, PTZ Speed Dome cameras, color touch-screen Voice over IP (VoIP) telephones, and multi-channel wireless LAN access points. Besides the wired Internet network, the wireless LAN would be more efficient for the transportation station to provide high-speed and wide area Internet services for travelers. By adopting PoE Wireless LAN structure, the transportation authority gains benefit from less cost while providing better Internet services in wider areas for the travelers.

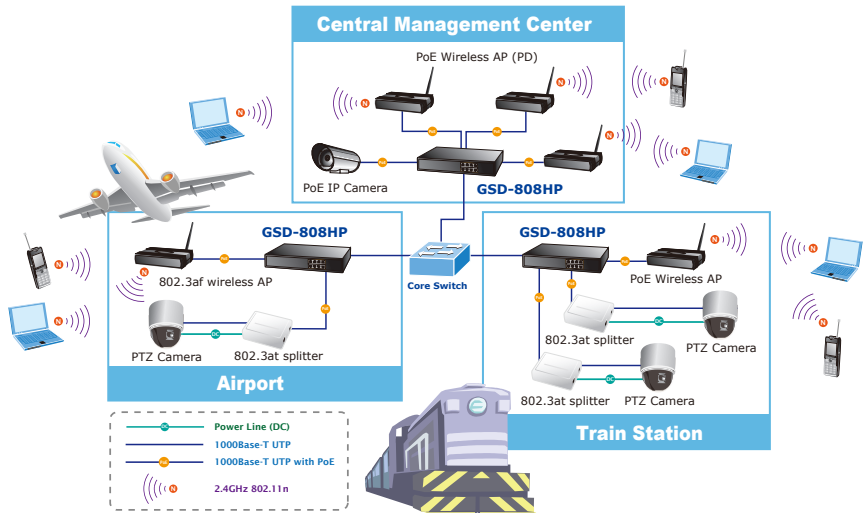

Figure 2-6: End Node or Switch Connection



Note

Cable distance for Switch

The cable distance between the GSD-808HP and other network equipments should not exceed 100 meter for UTP/STP cable.

Make sure the wiring is correct

It can be used Category 3/4/5 cable in 10 Mbps operation. To reliably operate your network at 100Mbps or 1000Mbps, you must use an Unshielded Twisted-Pair (UTP) Category 5/5e/6 cable, or better Data Grade cabling. While a Category 3 or 4 cables may initially seem to work, it will soon cause data loss.

2.5.2 IP Office

With the business office expansion, the additional telephones required could be installed in less cost via the implementation of PoE IP Telephony system than that of the traditional circuit wiring telephony system. PLANET GSD-808HP 802.3at Desktop PoE Switch helps enterprises to create an integrated data, voice, and powered network. PLANET IEEE 802.3af compliant IP Phones can be installed without the need of an additional power cable because the power can be provided via the standard Ethernet cable from the connected GSD-808HP. PoE IP Phones and Analog Telephony Adapter work perfectly with the GSD-808HP which injects power through the Ethernet cables.

With the GSD-808HP, IP Telephony deployment becomes more reliable and cost effective, which helps enterprises save tremendous cost when upgrading from the traditional telephony system to IP Telephony communications infrastructure.

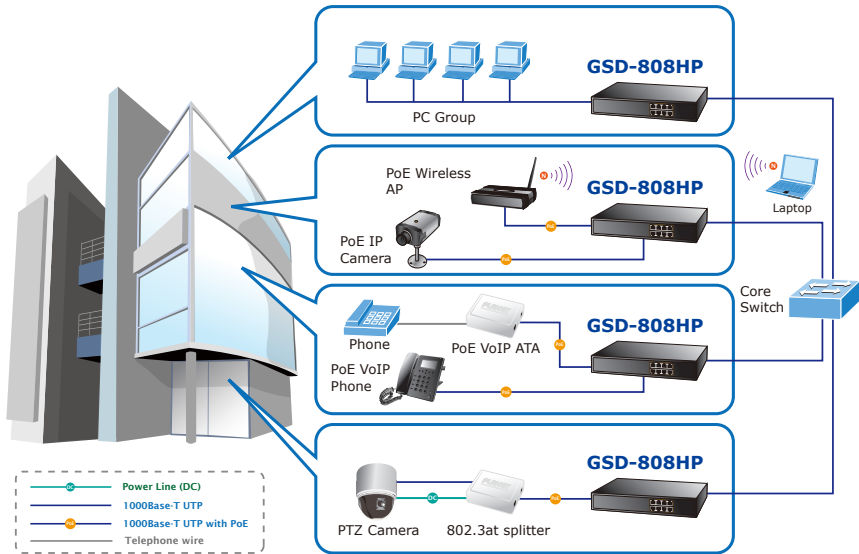







Figure 2-7: IP Office Department / Workgroup PoE Switch Connection

2.6 Power over Ethernet Powered Device

 <p>3~5 Watts</p>	<p>Voice over IP phones Enterprise can install POE VoIP Phone, ATA and other Ethernet/non-Ethernet end-devices to the central where UPS is installed for un-interrupt power system and power control system.</p>
 <p>6~12 Watts</p>	<p>Wireless LAN Access Points Museum, Sightseeing, Airport, Hotel, Campus, Factory, Warehouse can install the Access Point any where with no hesitation.</p>
 <p>10~12 Watts</p>	<p>IP Surveillance Enterprise, Museum, Campus, Hospital, Bank, can install IP Camera without limits of install location – no need electrician to install AC sockets.</p>
 <p>3~12 Watts</p>	<p>PoE Splitter PoE Splitter split the PoE 52V DC over the Ethernet cable into 5/12V DC power output. It frees the device deployment from restrictions due to power outlet locations, which eliminate the costs for additional AC wiring and reduces the installation time.</p>
 <p>3~25 Watts</p>	<p>High Power PoE Splitter High PoE Splitter split the PoE 52V DC over the Ethernet cable into 24/12V DC power output. It frees the device deployment from restrictions due to power outlet locations, which eliminate the costs for additional AC wiring and reduces the installation time.</p>



Note

Since the GSD-808HP per PoE port supports 56V DC PoE power output, please check and assure the Powered Device (PD) acceptable DC power range is from 52 to 56V DC. Otherwise, it will damage the Powered Device (PD).

3. Power over Ethernet Overview

What is PoE?

Based on the global standard IEEE 802.3af, PoE is a technology for wired Ethernet, the most widely installed local area network technology adopted today. PoE allows the electrical power necessary for the operation of each end-device to be carried by data cables rather than by separate power cords. New network applications, such as IP Cameras, VoIP Phones, and Wireless Networking, can help enterprises improve productivity. It minimizes wires that must be used to install the network for offering lower cost, and less power failures.

IEEE 802.3af also called Data Terminal equipment (DTE) power via Media dependent interface (MDI) is an international standard to define the transmission for power over Ethernet. The 802.3af is delivering 48V power over RJ-45 wiring. Besides 802.3af also define two types of source equipment: Mid-Span and End-Span.

Mid-Span

Mid-Span device is placed between legacy switch and the powered device. Mid-Span is tap the unused wire pairs 4/5 and 7/8 to carry power, the other four is for data transmit.

End-Span

End-Span device is direct connecting with power device. End-Span could also tap the wire 1/2 and 3/6.

PoE System Architecture

The specification of PoE typically requires two devices: the **Powered Source Equipment (PSE)** and the **Powered Device (PD)**. The PSE is either an End-Span or a Mid-Span, while the PD is a PoE-enabled terminal, such as IP Phones, Wireless LAN, etc. Power can be delivered over data pairs or spare pairs of standard CAT-5 cabling.

How Power is Transferred Through the Cable

A standard CAT5 Ethernet cable has four twisted pairs, but only two of these are used for 10BASE-T and 100BASE-T. The specification allows two options for using these cables for power, shown in Figure 2 and Figure 3:

The spare pairs are used. Figure 2 shows the pair on pins 4 and 5 connected together and forming the positive supply, and the pair on pins 7 and 8 connected and forming the negative supply. (In fact, a late change to the spec allows either polarity to be used).

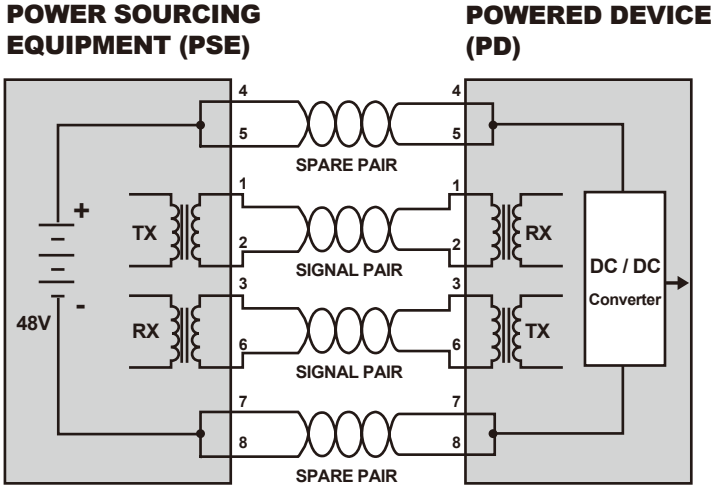

Figure 1 - Power Supplied over the Spare Pins

The data pairs are used. Since Ethernet pairs are transformer coupled at each end, it is possible to apply DC power to the center tap of the isolation transformer without upsetting the data transfer. In this mode of operation the pair on pins 3 and 6 and the pair on pins 1 and 2 can be of either polarity.

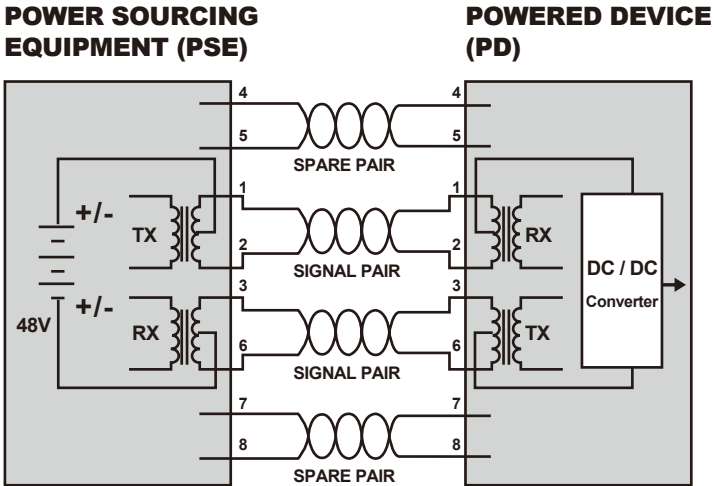

Figure 2 - Power Supplied over the Data Pins

When to install PoE?

Consider the following scenarios:

- You're planning to install the latest VoIP Phone system to minimize cabling building costs when your company moves into new offices next month.
- The company staff has been clamoring for a wireless access point in the picnic area behind the building so they can work on their laptops through lunch, but the cost of electrical power to the outside is not affordable.
- Management asks for IP Surveillance Cameras and business access systems throughout the facility, but they would rather avoid another electrician's payment.

References:

IEEE Std 802.3af-2003 (Amendment to IEEE Std 802.3-2002, including IEEE Std 802.3ae-2002), 2003 Page(s):0_1-121

White Paper on Power over Ethernet (IEEE 802.3af)

http://www.poweroverethernet.com/articles.php?article_id=52

Microsemi /PowerDsine

<http://www.microsemi.com/PowerDsine/>

Linear Tech

<http://www.linear.com/>

4. Troubleshooting

This chapter contains information to help you solve issues. If the Switch is not functioning properly, make sure the Ethernet Switch was set up according to instructions in this manual.

The Link LED is not lit

Solution:

Check the cable connection and remove duplex mode of the Switch.

Performance is bad

Solution:

Check the full duplex status of the Switch. If the Ethernet Switch is set to full duplex and the partner is set to half duplex, then the performance will be poor.

1000Base-T port link LED is lit, but the traffic is irregular

Solution:

Check that the attached device is not set to dedicate full duplex. Some devices use a physical or software switch to change duplex modes. Auto-negotiation may not recognize this type of full-duplex setting.

Why the Switch doesn't connect to the network

Solution:

Check the LNK/ACT LED on the switch Try another port on the Switch Make sure the cable is installed properly Make sure the cable is the right type Turn off the power. After a while, turn on power again.

Why I connect my PoE device to GSD-808HP and it cannot power on?

Solution:

Please check the cable type of the connection from GSD-808HP to the other end. The cable should be an 8-wire UTP, Category 5 or above, EIA568 cable within 100 meters. A cable with only 4-wire, short loop or over 100 meters, all will affect the power supply.

Please check and assure the device that fully complied with IEEE 802.3at / 802.3af standard.

What is the power output of each PoE port?

Solution:

1. Each PoE port supports **56V DC, 535mA, max 30 Watts** power output. Detect and inject by the standard of IEEE 802.3at.
2. Each PoE port supports **56V DC, 275mA, max 15.4 Watts** power output. Detect and inject by the standard of IEEE 802.3af.

Appendix A Networking Connection

A.1 PoE Switch RJ-45 Port Pin Assignments (Port 1 to Port-8)

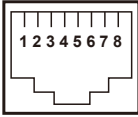
	PIN NO	RJ-45 SIGNAL ASSIGNMENT
	1	<ul style="list-style-type: none"> ● Output Transmit Data + ● Power +
	2	<ul style="list-style-type: none"> ● Output Transmit Data - ● Power +
	3	<ul style="list-style-type: none"> ● Receive Data + ● Power -
	4	-
	5	-
	6	<ul style="list-style-type: none"> ● Receive Data - ● Power -
	7	-
	8	-

A.2 Switch's RJ-45 Pin Assignments - 1000Mbps, 1000Base-T

Contact	MDI	MDI-X
1	BI_DA+	BI_DB+
2	BI_DA-	BI_DB-
3	BI_DB+	BI_DA+
4	BI_DC+	BI_DD+
5	BI_DC-	BI_DD-
6	BI_DB-	BI_DA-
7	BI_DD+	BI_DC+
8	BI_DD-	BI_DC-

Implicit implementation of the crossover function within a twisted-pair cable, or at a wiring panel, while not expressly forbidden, is beyond the scope of this standard.

A.3 10/100Mbps, 10/100Base-TX

When connecting your Switch to another Fast Ethernet switch, a bridge or a hub, a straight or crossover cable is necessary. Each port of the Switch supports auto-MDI/MDI-X detection. That means you can directly connect the Switch to any Ethernet devices without making a crossover cable. The following table and diagram show the standard RJ-45 receptacle/connector and their pin assignments:

RJ-45 Connector pin assignment		
Contact	MDI Media Dependant Interface	MDI-X Media Dependant Interface-Cross
1	Tx + (transmit)	Rx + (receive)
2	Tx - (transmit)	Rx - (receive)
3	Rx + (receive)	Tx + (transmit)
4, 5	Not used	
6	Rx - (receive)	Tx - (transmit)
7, 8	Not used	

The standard cable, RJ-45 pin assignment

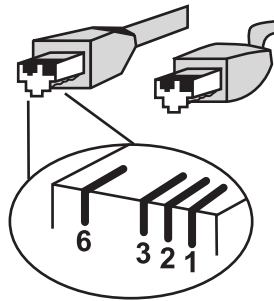

The standard RJ-45 receptacle/connector

There are 8 wires on a standard UTP/STP cable and each wire is color-coded. The following shows the pin allocation and color of straight cable and crossover cable connection:

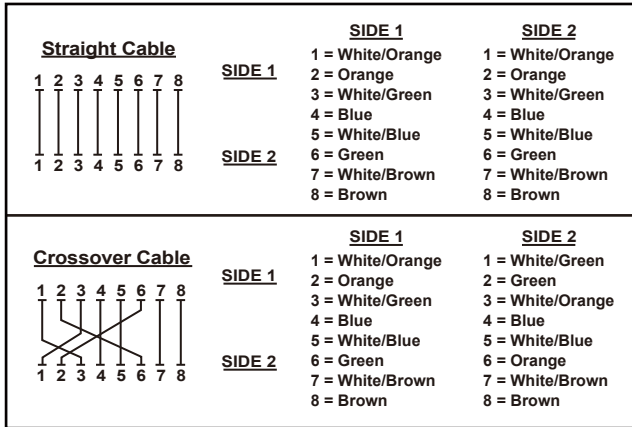

Figure A-1: Straight-Through and Crossover Cable

Please make sure your connected cables are with same pin assignment and color as above picture before deploying the cables into your network.



EC Declaration of Conformity

For the following equipment:

*Type of Product: 8-Port 10/100/1000Mbps 802.3at PoE Desktop Switch

*Model Number: GSD-808HP

* Produced by:

Manufacturer's Name : **Planet Technology Corp.**
Manufacturer's Address: 10F., No.96, Minquan Rd., Xindian Dist.,
New Taipei City 231, Taiwan (R.O.C.)

is herewith confirmed to comply with the requirements set out in the Council Directive on the Approximation of the Laws of the Member States relating to Electromagnetic Compatibility Directive on (2004/108/EC).

For the evaluation regarding the EMC, the following standards were applied:

EN55022	(2006 + A1:2007)
EN 61000-3-2	(2006 + A2:2009)
EN 61000-3-3	(2008)
EN55024	(1998 + A1:2001 + A2:2003)
IEC 61000-4-2	(2008)
IEC 61000-4-3	(2006 + A1:2007 + A2:2010)
IEC 61000-4-4	(2004 + A1:2010)
IEC 61000-4-5	(2005)
IEC 61000-4-6	(2008)
IEC 61000-4-8	(2009)
IEC 61000-4-11	(2004)

Responsible for marking this declaration if the:

Manufacturer Authorized representative established within the EU

Authorized representative established within the EU (if applicable):

Company Name: Planet Technology Corp.

Company Address: 10F., No.96, Minquan Rd., Xindian Dist., New Taipei City 231, Taiwan (R.O.C.)

Person responsible for making this declaration

Name, Surname Kent Kang

Position / Title : Product Manager

Taiwan

Place

14th Oct., 2011

Date

Legal Signature

PLANET TECHNOLOGY CORPORATION

e-mail: sales@planet.com.tw http://www.planet.com.tw

10F., No.96, Minquan Rd., Xindian Dist., New Taipei City, Taiwan, R.O.C. Tel:886-2-2219-9518 Fax:886-2-2219-9528